

# Wide Body Adapter Brackets

## Installation Instructions

For Anchoring Wide Body Vehicles

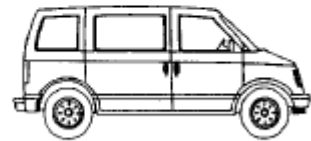
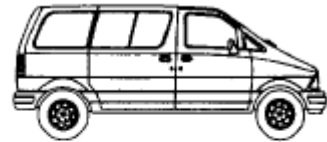
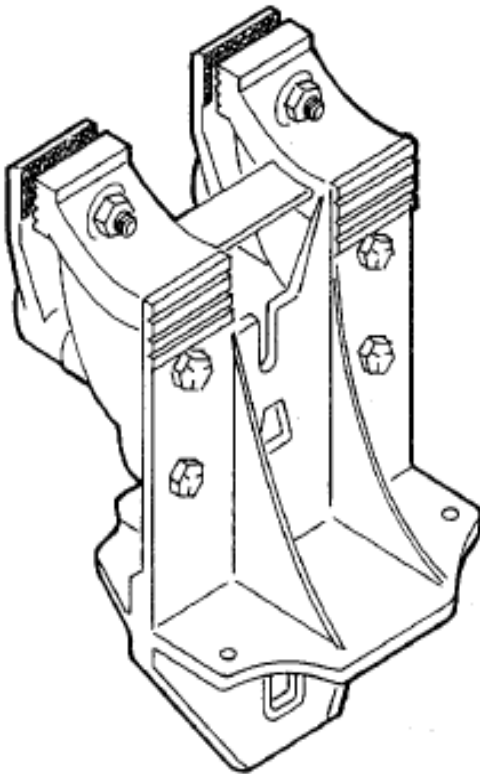

Wedge Clamp Systems Inc. 170-21320 Gordon Way, Richmond, BC V6W 1J8  
Tel: (604) 207-9595 | Fax: (604) 207-9593 | Toll Free: 1-800-615-9949

## Installation of Wide Body Adapter Brackets

1. To install three brackets remove the two jaws from the pinchweld clamp. Using the four 1 ½" (38 mm) bolts supplied, bolt the Wide Body Adapter Bracket to the outside face of the Clamp as shown. Replace the two jaws onto the Bracket as shown with the two 3" (76 mm ) bolts supplied.

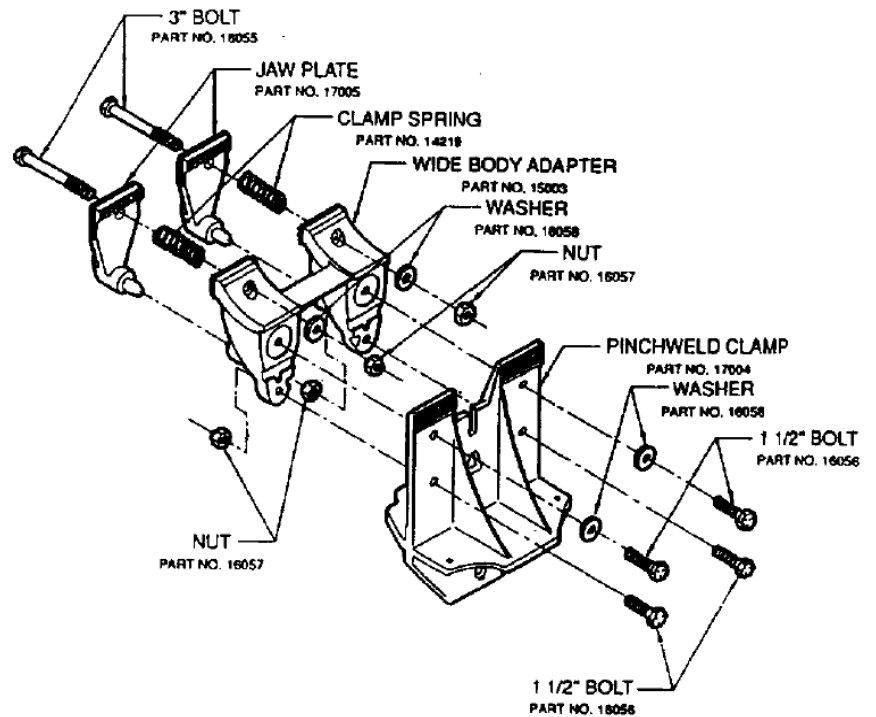

2. Install the pinchweld clamp onto the Pinchweld as usual . Proceed with the standard setup procedure as shown in the wedge clamp Training manual " Setting up the Anchoring system."

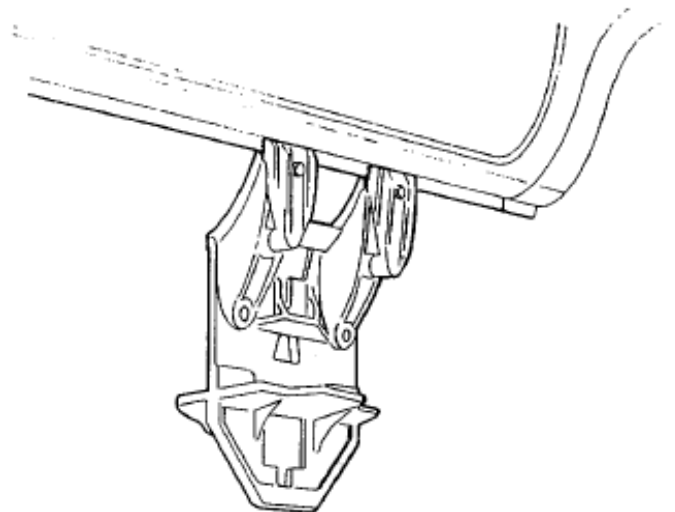



**WARNING:** Serious damage or injury can occur if the vehicle is not anchored securely for pulling. It is your responsibility to evaluate the car and determine the safest anchoring method. Always check the anchoring points during pulling to be sure that the car remains securely anchored. Heavy upward or downward pulls may require that additional clamping holds be made, or that the frame be supported in certain places to prevent damage to the vehicle.

## Vehicle Specifications

The Wedge Clamp Wide Body Adapter Kit is used for anchoring wide unibody vehicles and vans with pinchweld spacing up to  $75\frac{3}{4}$ " (1925 mm). Each adapter widens the pinchweld clamp 4" (100 mm) for a total width increase between the pinchweld clamp jaws of 8" (200 mm). The vehicle must have a reinforced structural pinchweld capable of withstanding the weight of the vehicle plus any pulling forces.

