

WEDGE CLAMP TRAINING PROGRAM

1. Damage Diagnosis
 - Evaluating primary and secondary damage
2. Dealing with Suspension and Mechanical Components
 - Their affect on total vehicle alignment
3. Anchoring Systems/Problems
 - Horizontal pinchwelds
 - Small unitized trucks
 - Mini vans
 - Sport utility vehicles
4. Measuring Principles
 - Body & suspensions
5. Pulling and Straightening Systems
6. Pulling Techniques
7. How to repair specific types of damage
 - Side hits, twists, roll overs, vehicles damaged heavily in the cowl, front hinge pillar
8. Summary with Review Test

Course Duration: 8 hours

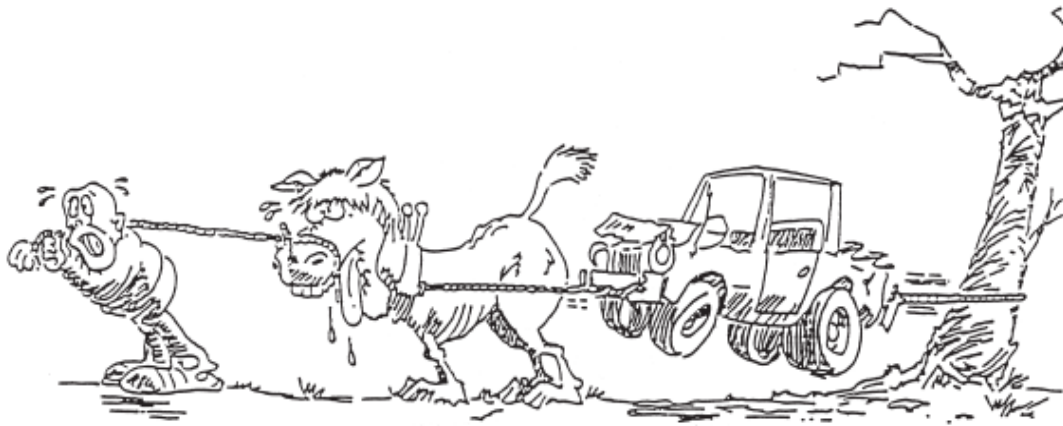

...never stand in the line of the pulling force!

Wedge Clamp Systems Inc. 170-21320 Gordon Way, Richmond, BC V6W 1J8
Tel: (604) 207-9595 | Fax: (604) 207-9593 | Toll Free: 1-800-615-9949

VEHICLE DESIGN

Frame Vehicles

- Traditionally vehicles were of a separate frame and body type construction.
- These cars react differently in an accident to that of the modern unibody.
- Suspension mounted directly to the frame.
- Suspensions had lots of adjustment
- Easy to get a wheel alignment.

Unibody Vehicles

- One integral unit
- Aircraft type construction
- Shaped structural panels welded together
- Gets its strength from:
 - Each adjoining welded panel.
 - The shape and design of the panels.
 - Even the windshield is part of the structure.
- Uses thin high strength steels which must be repaired differently.
- Most vehicles should have 4-wheel alignment.
- Less wheel alignment adjustment on suspension parts and parts mounted directly on the body.
- The bodyman (panelbeater) must think of total body alignment as well as wheel alignment.

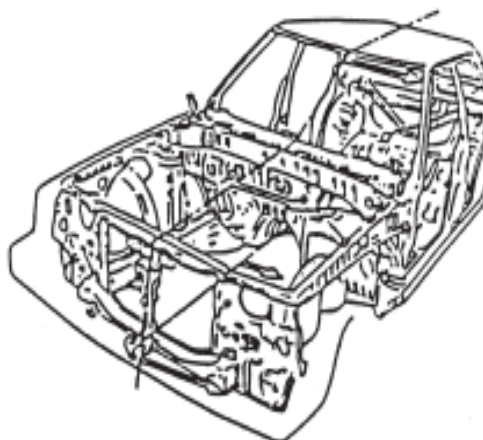
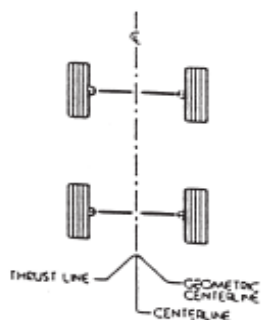
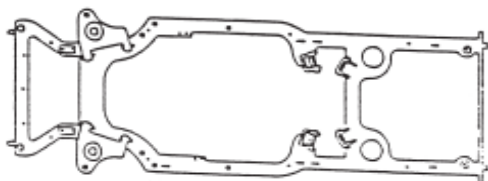

THE COLLISION FORCE

- Collision Force is distributed though out the shape of an object and is affected by varying strengths, shapes and attached components.

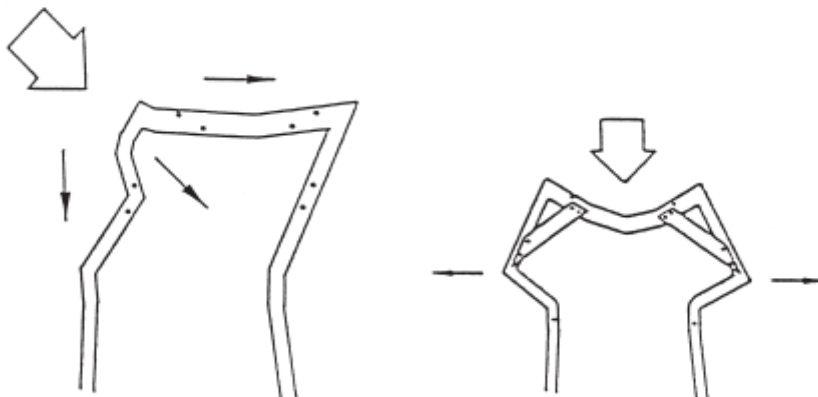

- The Unibody controls the collision force.
- It absorbs and transmits the energy force round the passenger compartment.
- The unibody is designed with:
 1. Crush Zones
 2. Rigid Zones

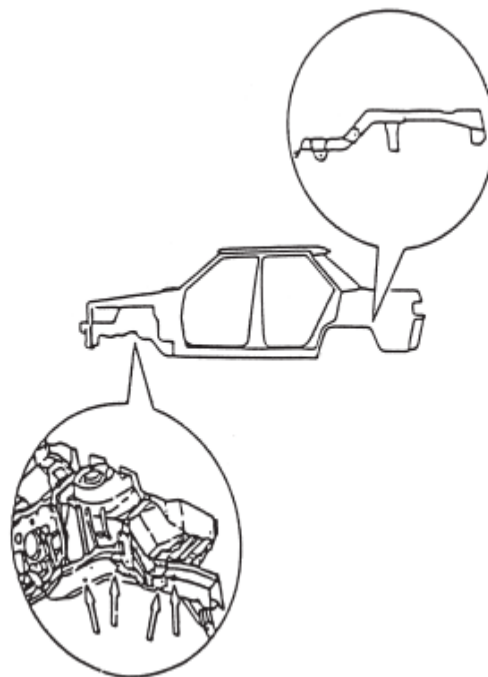



- The biggest problems in the bodyshop is getting the car back to the customer on time.
- The major reason. Back ordered parts.
- Why? Missed on original estimate.
- Incorrect damage analysis.
- Repairing something that was missed on the estimate.
- Not repairing it right the first time. Reworks.
- Taking too long to repair the car.

WHAT HAPPENS IN AN ACCIDENT

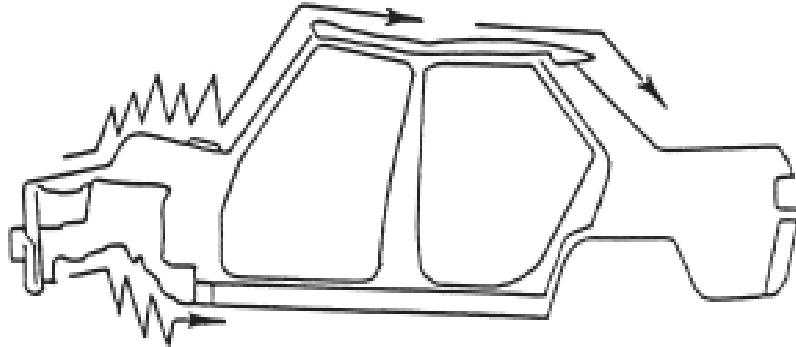

- How does it affect the vehicle?
 1. The collision force is absorbed.
 2. The fenders and hood (bonnet) buckle.
 3. The frame rails collapse.
 4. The engine moves back and drops down.
 5. The collision force is dissipated outside and around the passenger compartment.
 6. Unlike the frame car, damage is now transferred into areas far beyond the point of impact.

VEHICLE FOUNDATION

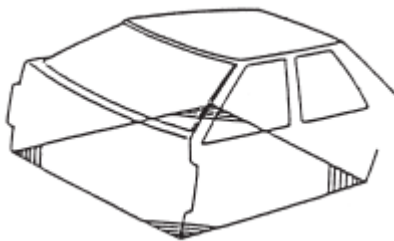

- Because of the safety features, crush zones and rigid zones, we have very strong areas of a car.
- The strongest part of a unibody is the four corners of the floor pan. The four lower corners of the passenger compartment.
- This area is the foundation of the car.
- This area must be repaired first.
- This is where we clamp onto the car.

TYPES OF DAMAGE AND WHERE TO FIND IT

Types of Damage - Direct and Indirect

- Direct or primary damage is the damage in the area of impact. It is easy to find.
- Indirect or secondary damage. Damage that is caused by the collision force being transmitted through the vehicle and into other areas far away from the area of impact. It can also be caused by inertia.

Inertia is where an object or part of the vehicle continues in a forward motion while the rest of the car has been stopped.

Things to look for:

- We can look for misaligned doors, hoods or trunk lids.
- Look for a raised roof.
- Kinks in the roof on the side above the center post.
- Flat spots in the middle of the roof. This is often overlooked and missed during the estimate. This is extremely common in late model vehicles particularly the smaller vehicle as the roof is pushed back on one side causing a twist in the roof which brings the flat spot in the middle of the roof panel. This is more common with some vehicles than finding a kink on the side edge.
- Kinks or creases in the sail panel where it meets the quarter panel. This is from a front end collision where the damage is transferred through the vehicle.
- Another very commonly overlooked area is that of a twist in the torque box area. The front of the sill panel will twist up or down. This twist is often small say 5, 10, or 15 mm and is often undetected as the sheet metal will still fit but it can cause problems later with water leaks and wind whistles as the rubber seals no longer sit properly against the pillars, etc.
- Look for any ripples or kinks in sheet metal panels that are far away from the area of impact. Example, in a collision the roof will ripple like a wave on a beach, this has been noticed watching crash tests in slow motion. It gives us an idea of how the damage is transferred through the vehicle.
- Cracked or split seam sealers.
- Misaligned side and roof moldings.
- The seat tracks. Seat back rests.
- Door glass often drops out of window tracks.
- Interior dash panel.
- Mechanical and Electrical.

DAMAGE TRANSFERRED BY MECHANICAL PARTS

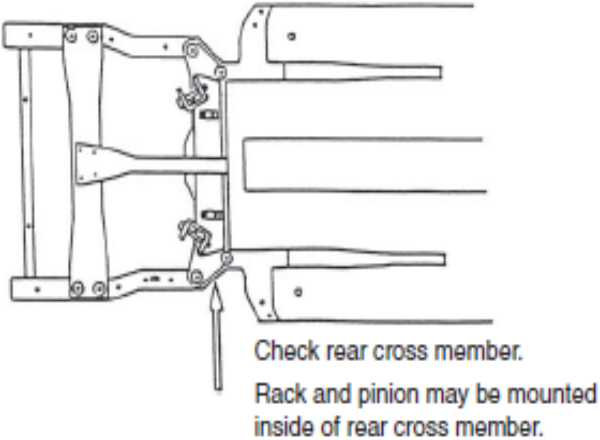
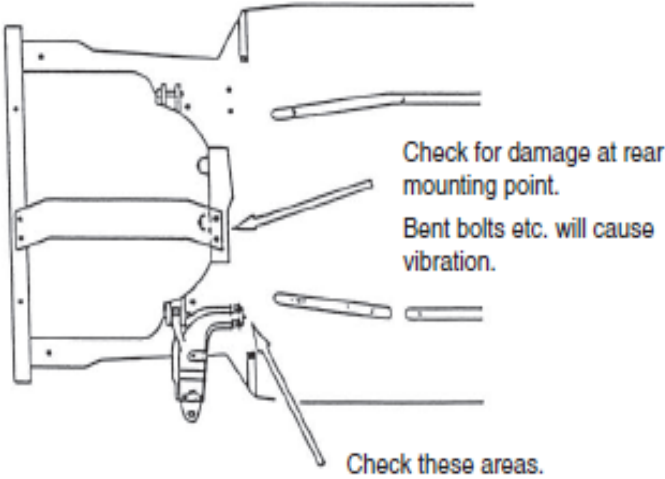
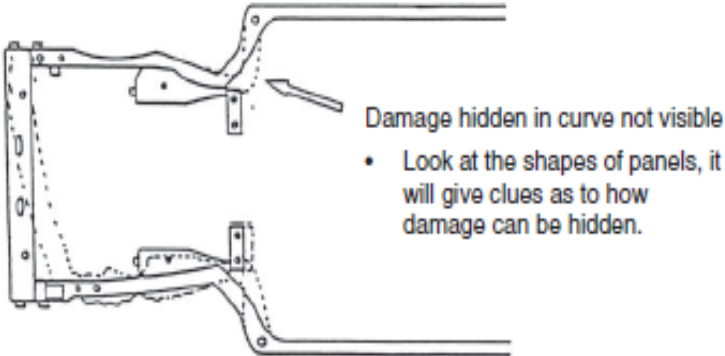

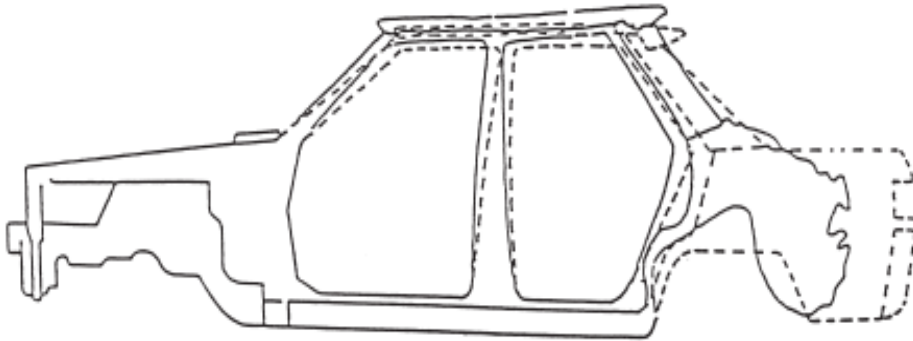

- Raised roof.
- Torque box may twist up.
- Roof may move forward on one side.
- Center hinge pillar moved forward and makes it look as though the front door has dropped.

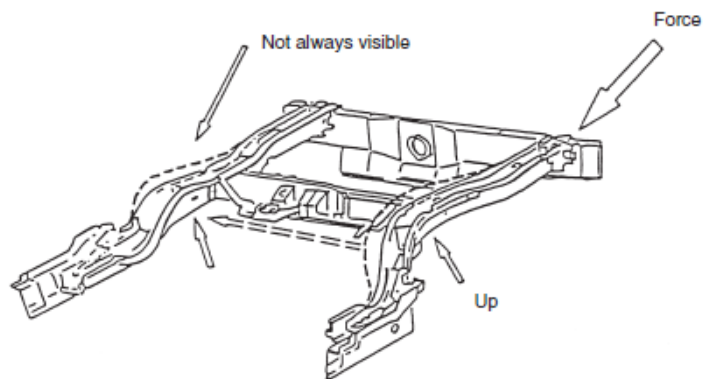

- Although not common, this does happen on occasion.

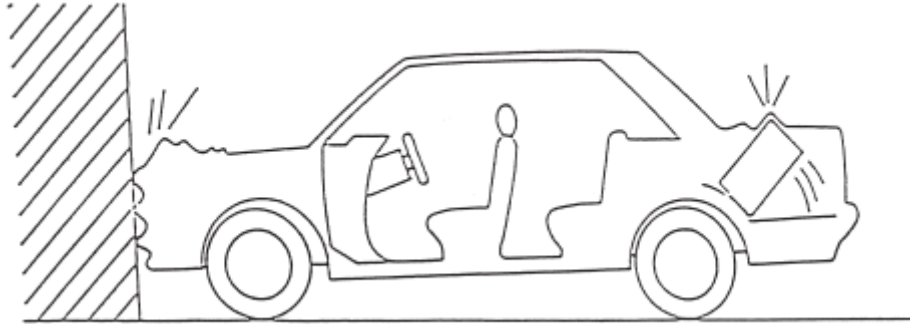

- Look for transferred structural damage first.
- Damage from objects in trunk (boot).
- Seat tracks (very common on small cars).
- Seat back rests.
- Check all door glass, often jumps out of track.
- Dash and interior trim.
- Steering shaft.

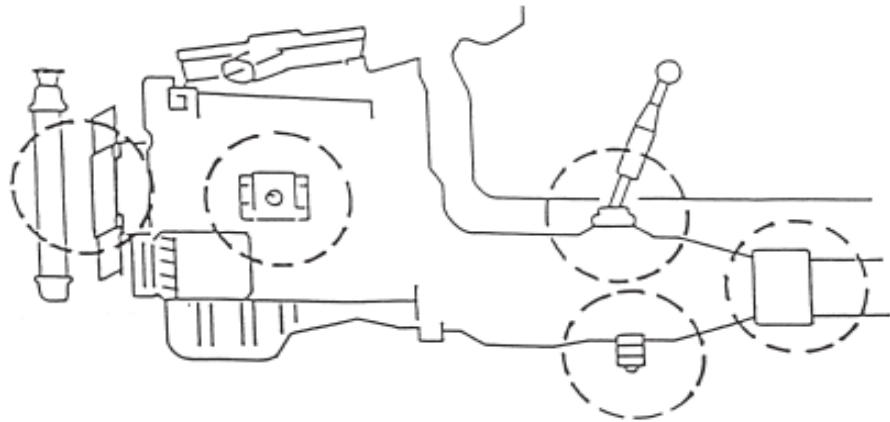

WHERE THE VEHICLE IS HIT

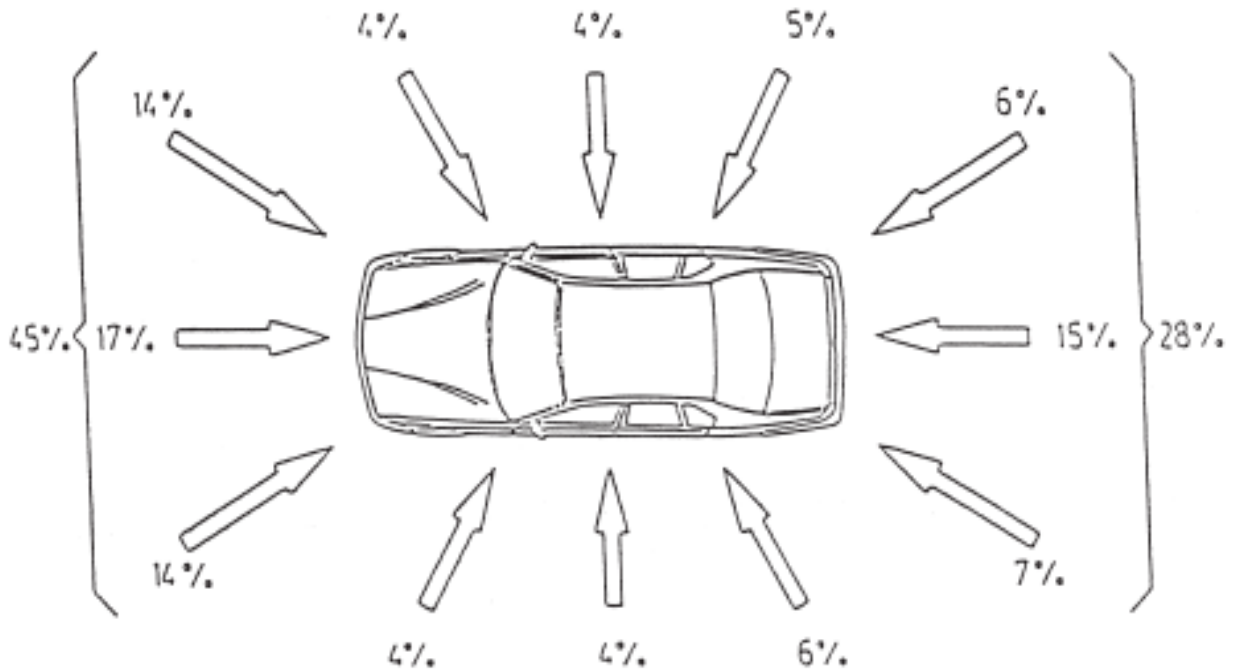

Based on a study of 89,000 accidents

UNDERBODY MEASURING

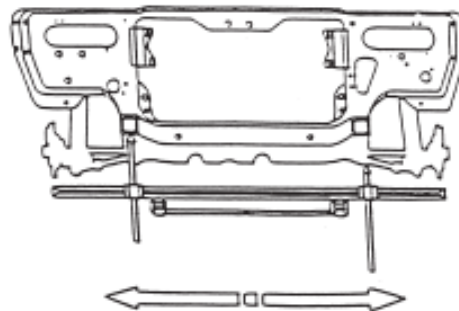
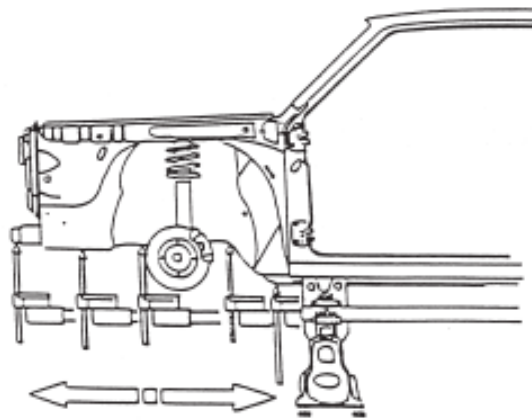
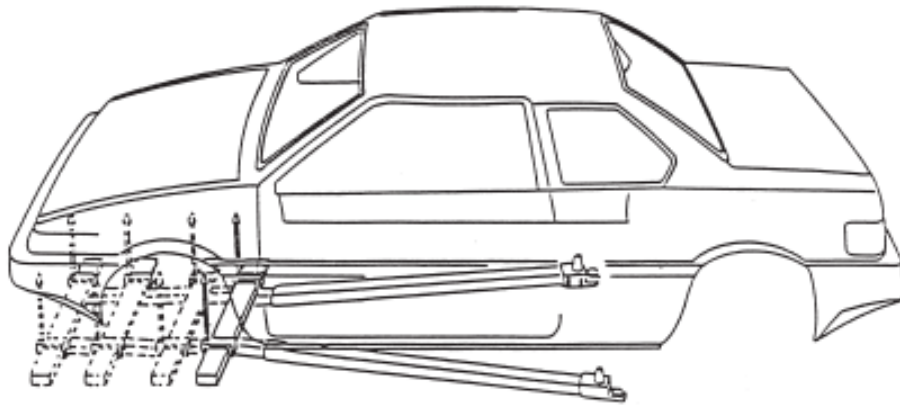

TOTAL UPPER BODY MEASURING

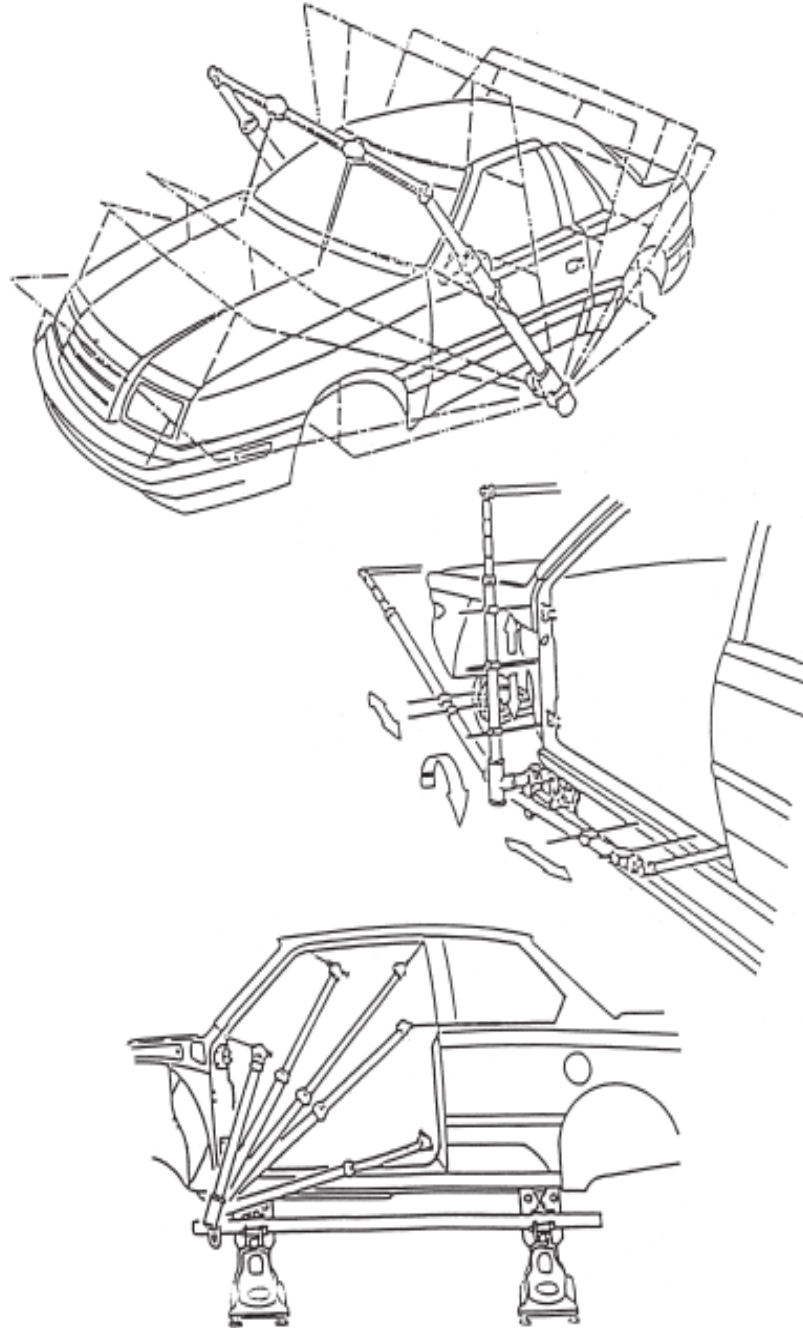

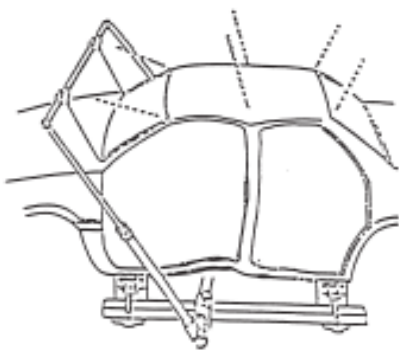

Pre-alignment check and bump steering.

Bump steer caused by damaged or misaligned suspension and steering parts.

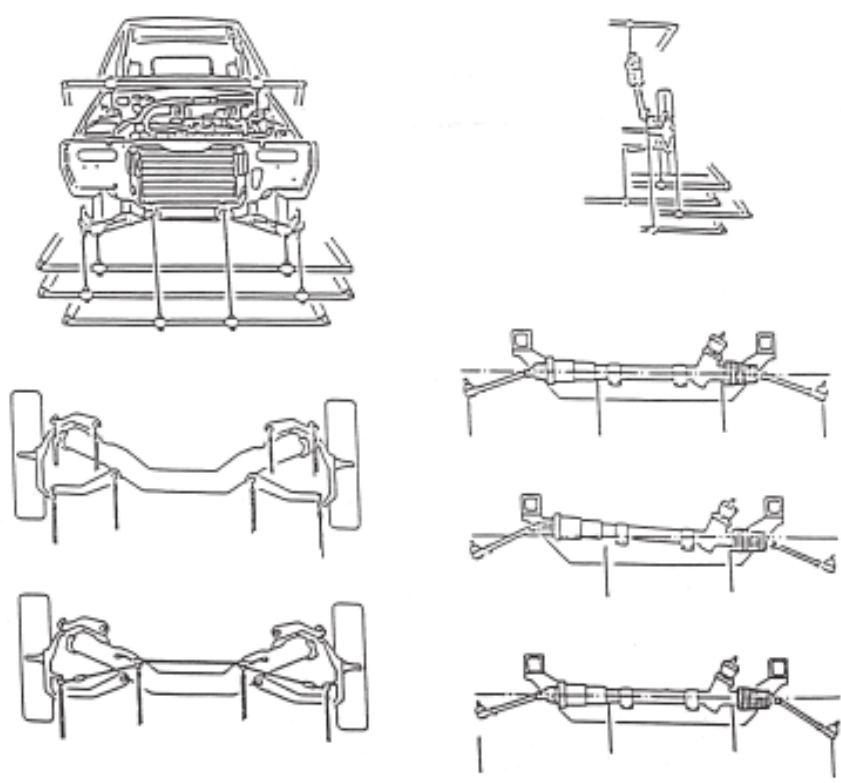

This is a steering gear check.



Step 1 Turn the road wheels so that they are facing the front or in a straight line. Center it with the steering wheel centered.

Step 2 Leave the steering lock undone.

Step 3 Bounce the car up and down at the front.

Step 4 While bouncing the vehicle, look at the steering wheel. If the steering wheel moves from side to side up to maybe an inch, there is possible no steering gear damage. However, if the movement is more than one inch, say up to six inches or anywhere in between there is definitely steering gear damage.



Checking for a bent strut.

1. Loosen off the top nut of the strut.
2. Position yourself at the side of the vehicle looking at the edge of the fender and lining it up with the edge of the wheel.
3. Rotate the strut with a wrench. If the movement of the tire moves in and out more than approximately $\frac{1}{16}$ " , then there is damage to the strut and needs to be replaced. The movement here should be very minimal, even less than $\frac{1}{16}$ " .

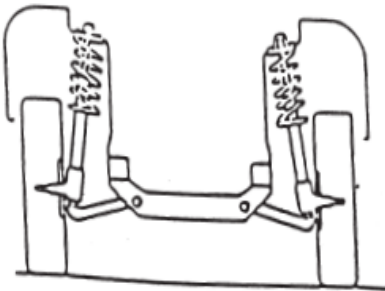

It is a very simple test and will show up damage if it is of a more severe nature. Simply a matter of bending down and placing your fingers between the strut and the road wheel or tire on each side. If you can get more fingers in on one side than the other, the shorter side is definitely damaged and needs to be replaced.