

EZE ROLLER

10 TON PULLING MACHINE

Assembly Instructions & Replacement Parts List

Assembly Instructions	1
Important Safety Information	7
Parts Diagram	9



WARNING:

All safety precaution statements on the air/hydraulic pump operation instruction supplied must be carefully observed to help prevent personal injury.

Wedge Clamp Systems Inc. 170-21320 Gordon Way, Richmond, BC V6W 1J8
Tel: (604) 207-9595 | Fax: (604) 207-9593 | Toll Free: 1-800-615-9949



EZE ROLLER ASSEMBLY INSTRUCTIONS

- Place left the right channel on the floor as shown

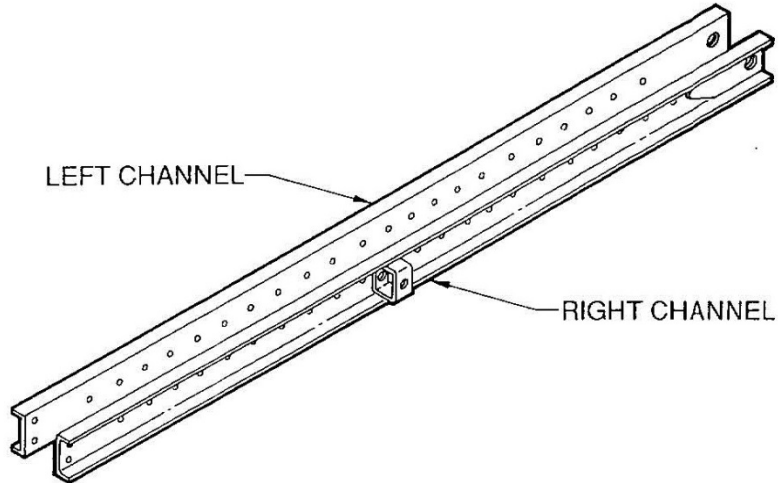

- Place Eze Roller base and ram carriage onto the channels in the positions as shown.

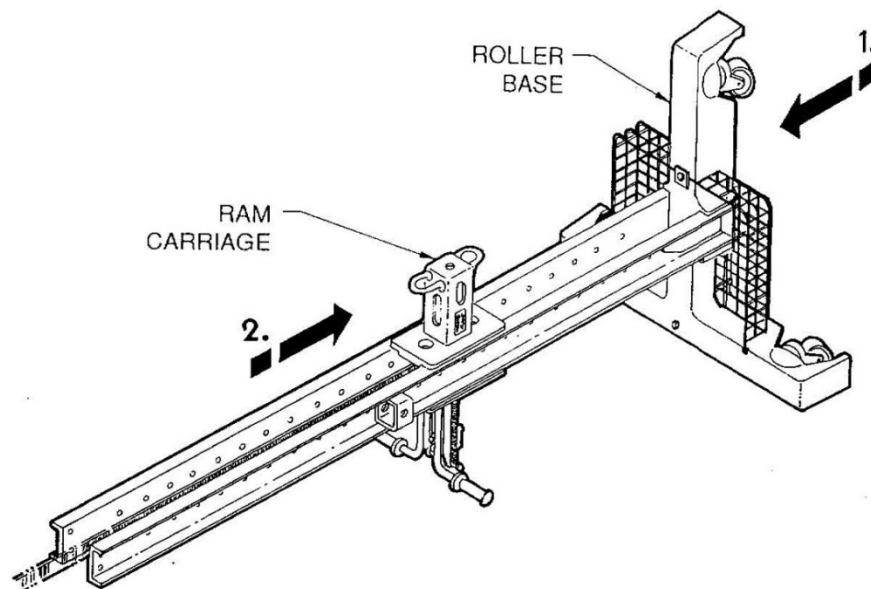

EZE ROLLER ASSEMBLY INSTRUCTIONS

3.

- Insert the channel mounting bolt through the large hole in the bottom of the channels and through the Eze Roller base. Place the nut on the end of the channel mounting bolt, but do not tighten the nut yet.
- Loosely insert the two channel wedges under the channel between the base of the channels and the Eze Roller base as shown,

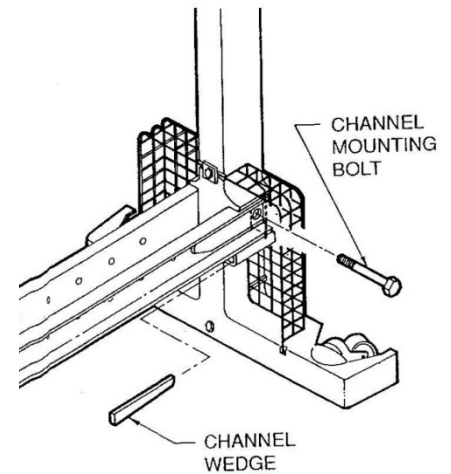

4.

- Take the loose end of the black nylon strap which is attached to the ram carriage and thread the strap through the roller cap rollers.
- Install the roller cap and tighten the four roller cap bolts as shown.

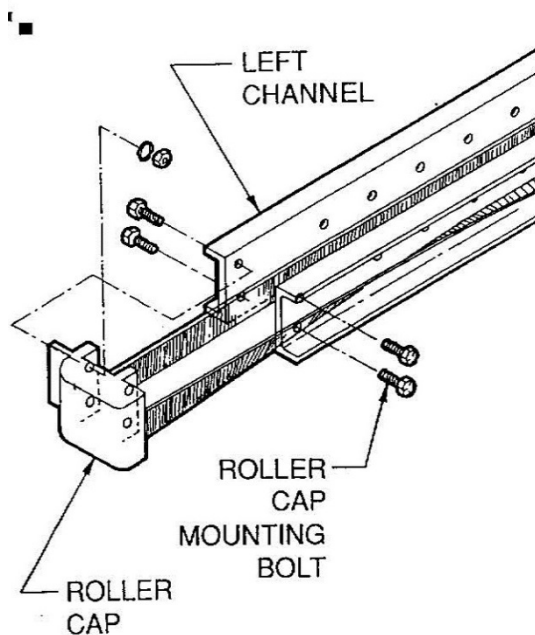

EZE ROLLER ASSEMBLY INSTRUCTIONS

5.

- Slide the ram carriage towards the Eze Roller base as shown

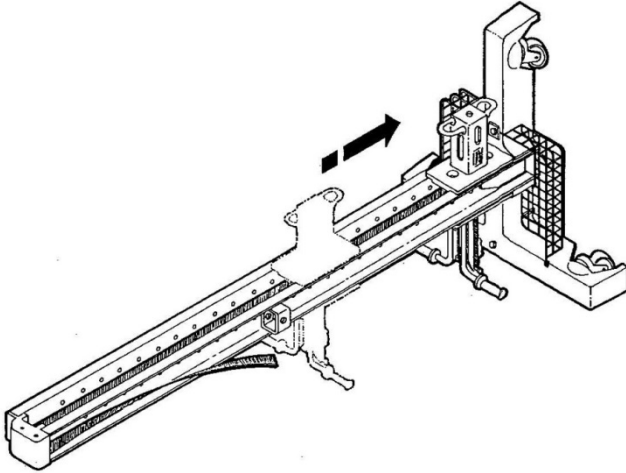

6.

- Stand the Eze Roller into the vertical position as shown.
- Hammer in the two channel wedges at the base of the channel
- Tighten the channel bolt and nut

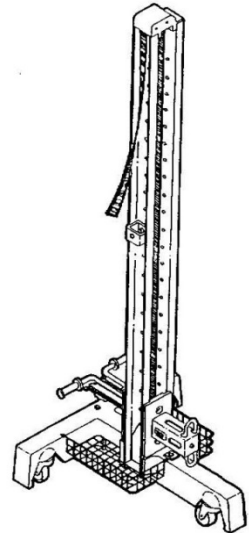

EZE ROLLER ASSEMBLY INSTRUCTIONS

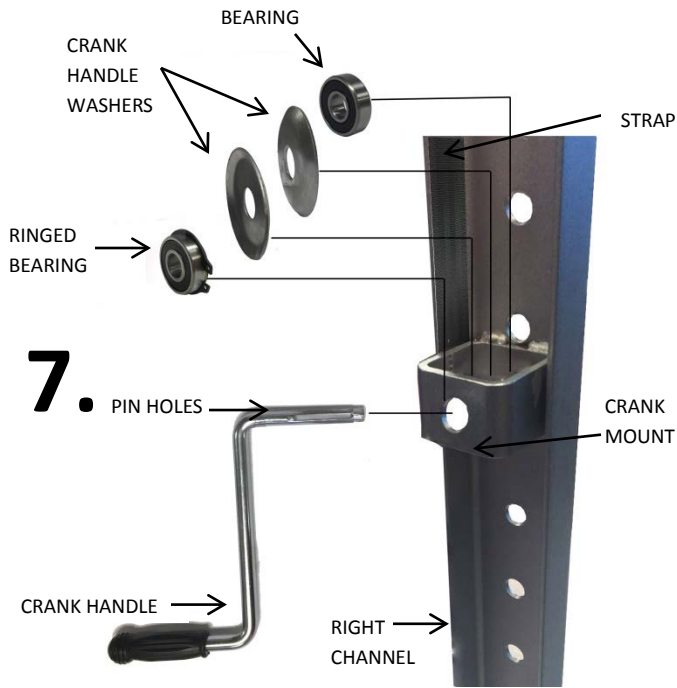

- Fit the ringed bearing and the bearing into the hole in the crank mount bracket from the inside of the bracket. As seen in the picture the bearing faces should be flush to the outside face of the bracket.
- Insert the crank handle into the crank mount bracket as shown.
- Place the two crank handle washers on the slotted crank shaft on either side of the black strap.
- Be sure to mount the washers so that the bevel flanges on the washers angle AWAY from the strap.

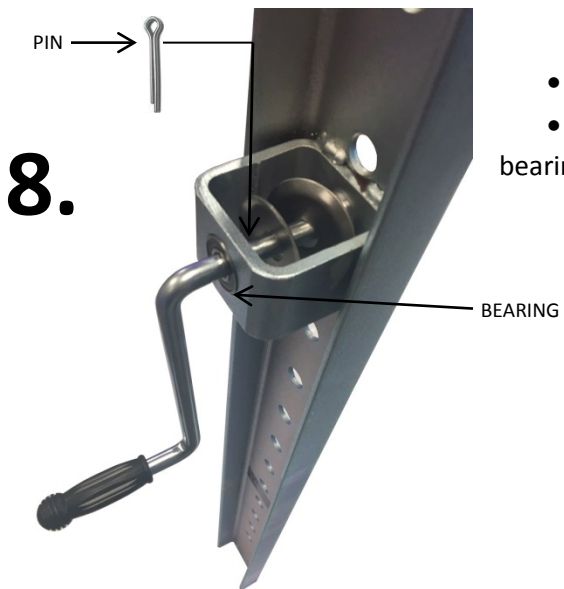

- Install the split pin into the crank shaft pin hole.
- The pin goes between the outer crank handle washer and the ringed bearing as shown.

EZE ROLLER ASSEMBLY INSTRUCTIONS

9.

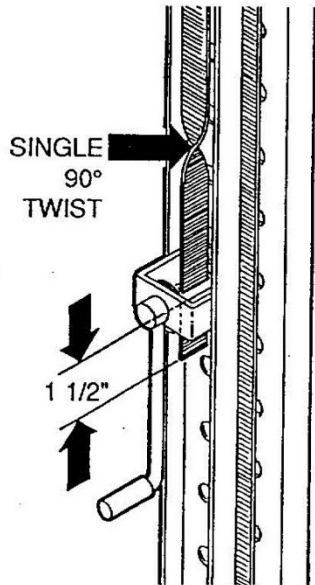

- Turn the strap so that it has a single 90° twist, and thread 1 1/2 inches (4 cm) through the slot of the crank handle as shown.

10.

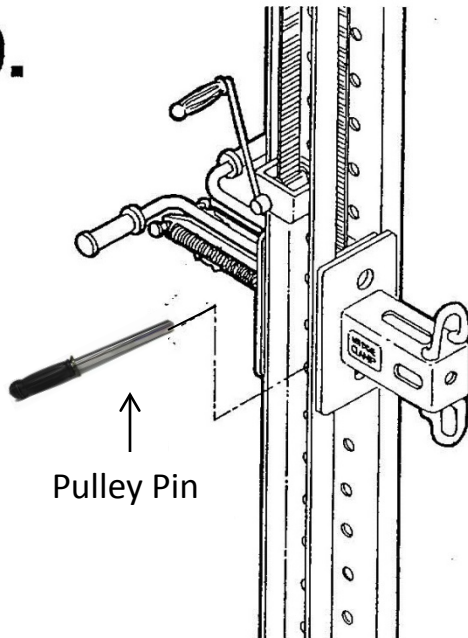

- Turn crank handle clockwise to wind the strap on the crank shaft. Continue to turn the crank handle clockwise to raise the ram carriage up.
- Set the ram carriage pulling height as shown by inserting the Pulley Pin under the ram carriage and through the holes in the channels
- Set the ram carriage about three feet from the floor when not in use.

⚠ CAUTION:

Always hold the crank handle firmly before removing the Pulley Pin otherwise handle will spin violently which could cause personal injury.

EZE ROLLER ASSEMBLY INSTRUCTIONS

11.

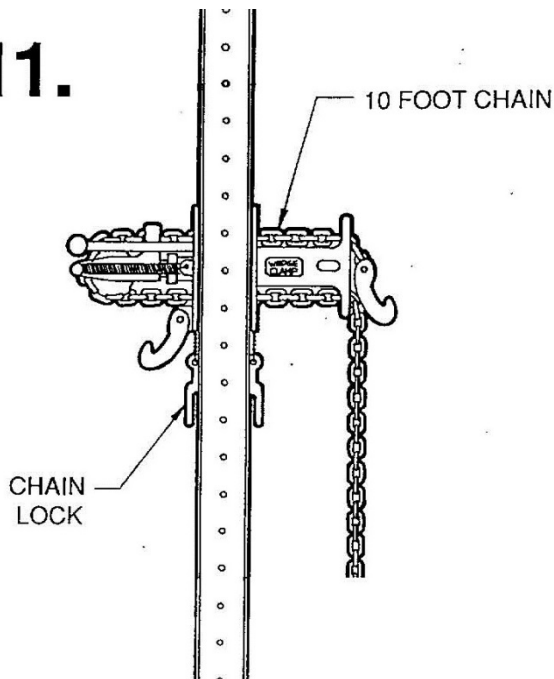

- Install the 10 foot chain through the ram carriage as shown. Be careful that there is no twist in the chain as it passes through the ram carriage.
- The chain locks are used to hold a pull on a chain; or to continue pulling on one chain while the other chain holds a steady pull pressure.

12.

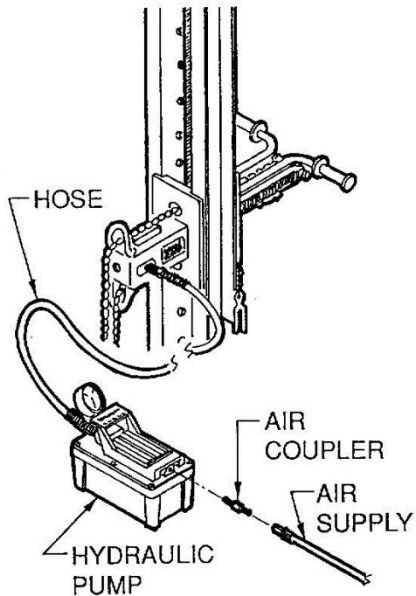

- Attach the hydraulic pump hose to the hydraulic ram as shown. Attach an air hose coupling to the hydraulic pump which is suitable for the air supply hose coupling being used.

IMPORTANT SAFETY INFORMATION

CAUTION:

The hydraulic reservoir in the pump must be vented prior to use. Please refer to re-priming the pump instructions located in Pump User Manual.



WARNING:

- Airline pressure should never be greater than 110 P.S.I. (7.5 bar, 758 kPa). Pressure over 110 P.S.I. can cause the hydraulic ram to overpull which can result in breakage and risk of personal injury.

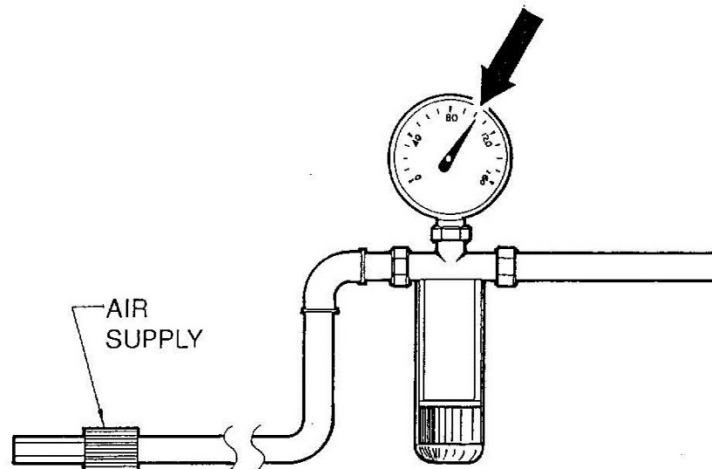

IMPORTANT SAFETY INFORMATION

WARNING :

- Don't stand behind the puller and keep clear of chain when under pressure.
- Always connect the safety strap to the vehicle and the puller.
- Always hold crank handle firmly while ram carriage pin is removed.
- Be sure that there are no twists in any of the chains when pulling.
- Airline pressure must never be greater than 110 P.S.I. (758 kPa)
- When making a downward pull the chain from the vehicle can not have a greater downward angle than the tie-down chain running to the floor.
- Use only the chain supplied with this puller or replacement chain supplied by Wedge Clamp.
- Do not use pulling hooks or chain which are cracked, fractured, bent or damaged.

Failure to follow these procedures can cause physical injury or death.

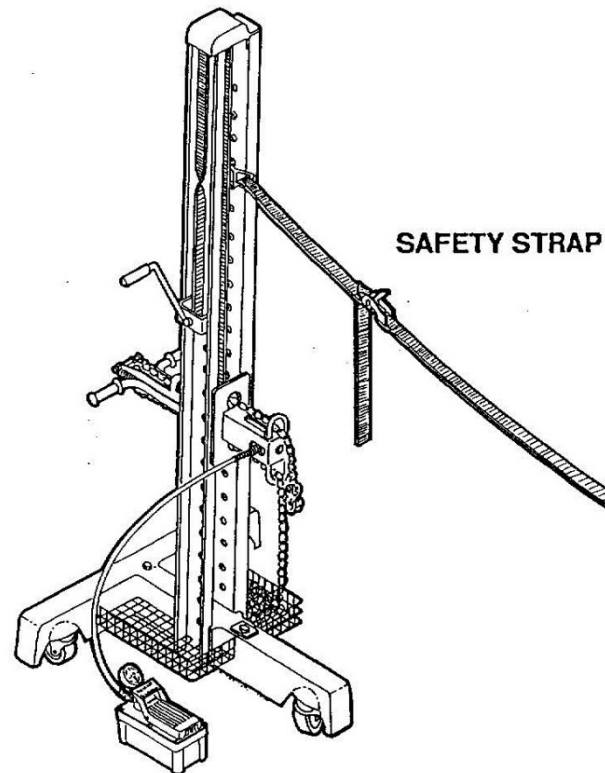

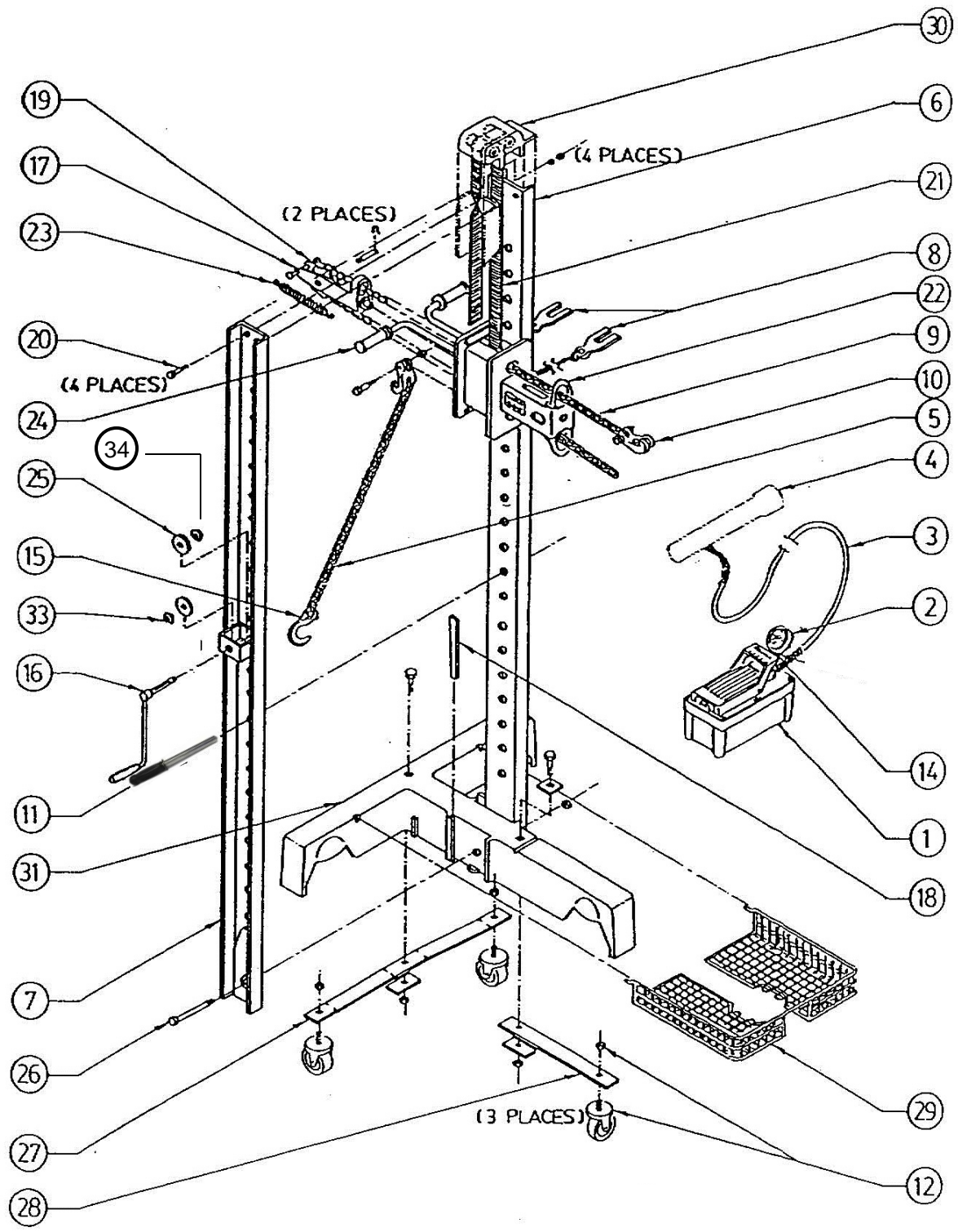

ITEM NO.	NEW PART NO.	NO. REQ'D	DESCRIPTION
1.	20054	1	Hydraulic Pump
2.	20113	1	Pressure Gauge
3.	20053	1	Hydraulic Hose
4.	20014	1	Hydraulic Ram
5.	21009	1	8 ft. Grade 80 Anchoring Chain
6.	13011	1	7 ft. Steel Channel (Left)
7.	13012	1	7 ft. Steel Channel (Right)
(Note: crank handle mount on the right channel)			
8.	20061	2	Chain Lock
	13035		Chain
	16035		Lock Washer
9.	21009	1	10 ft. Pulling Chain
10.	09067	1	Claw Hook with bolt and nut
11.	20055	1	Pulley Pin
12.	13018	3	Castor Wheel
14.	20111	1	Hydraulic Tee Fitting
15.	21007	1	3/8" Clevis Grab Hook
16.	13038	1	Crank Handle
17.	13044	1	Pulley Bracket
18.	13032	2	Channel Locking Wedges
19.	21001	1	Pulley (3/8")
20.	16025	4	Roller Cap Mounting Bolt
	16004	1	Roller Cap Mounting Nut
21.	13034	1	10 ft. Black Nylon Strap
22.	13036	1	Ram Carriage
23.	20003	2	Ram Return Springs
24.	20101	2	Handle Grip
25.	16036	2	Crank Handle Washer
26.	16013	1	Channel Mounting Bolt
	16012	1	Channel Mounting Nut
27.	13014	1	Rear Spring
28.	13016	1	Front Spring
29.	13021	1	Chain Basket
30.	13050	1	Roller Cap
31.	13013	1	Eze Roller Blue Base
33.	13063	1	Ringed Bearing
34.	13007	1	Bearing
1, 2, 3,14	20045	1	Pump Assembly with Hose includes: (1) 20111; (1)20113; (1) 20053; (1)20054

