

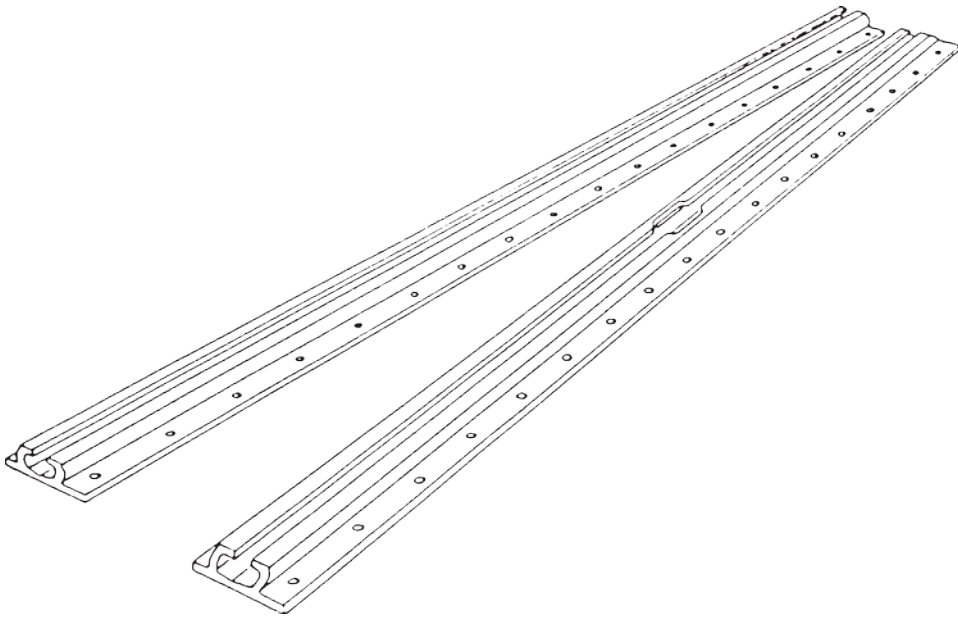

ANCHORING RAIL LAYOUTS & INSTALLATION INSTRUCTIONS

	Page
Repair Bay Layout.....	1
Installation Procedure for Flush Mounted Rails when Pouring New Floors.....	3
Flush Mounting Rails by Cutting Into Existing Floors.....	6
Surface Mounting Onto Existing Floors	9





REPAIR BAY LAYOUT

SURFACE MOUNTED RAILS (ON TOP SURFACE OF CONCRETE FLOOR) (Note that these are recommended layouts only. You may wish to vary the layout depending on your particular circumstances or type of work you are performing.)

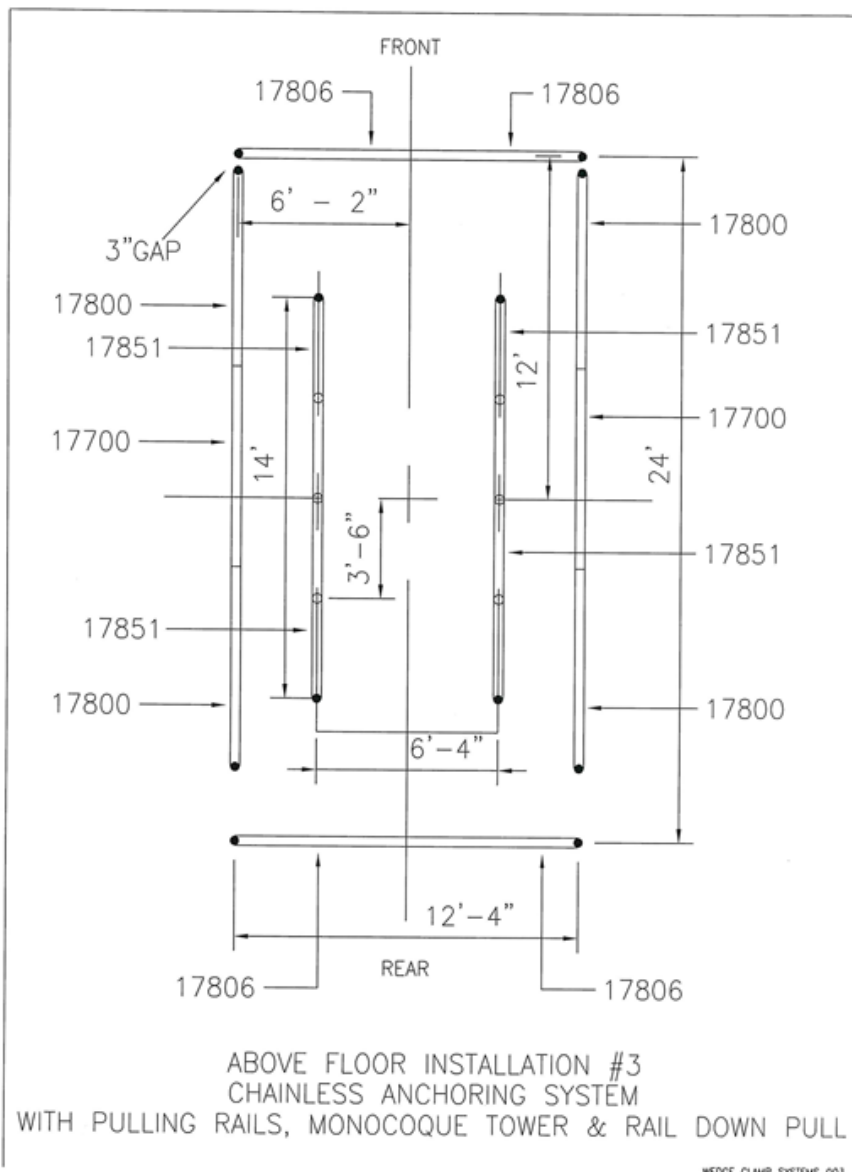

SEE WEBSITE
FOR NEW
UPDATED
BAY LAYOUTS

Note: * Minimum width for the Monocoque Pulling Tower only. If using Eze Roller Pulling Towers use a minimum bay width of 14' (4.27 m). Refer to wedge Clamp Bay Layouts for detailed measurements.



REPAIR BAY LAYOUT

FLUSH-MOUNTED RAILS (SET INTO THE CONCRETE FLOOR)
 (Note that these are recommended layouts only. You may wish to vary the layout depending on your particular circumstances or type of work you are performing.)

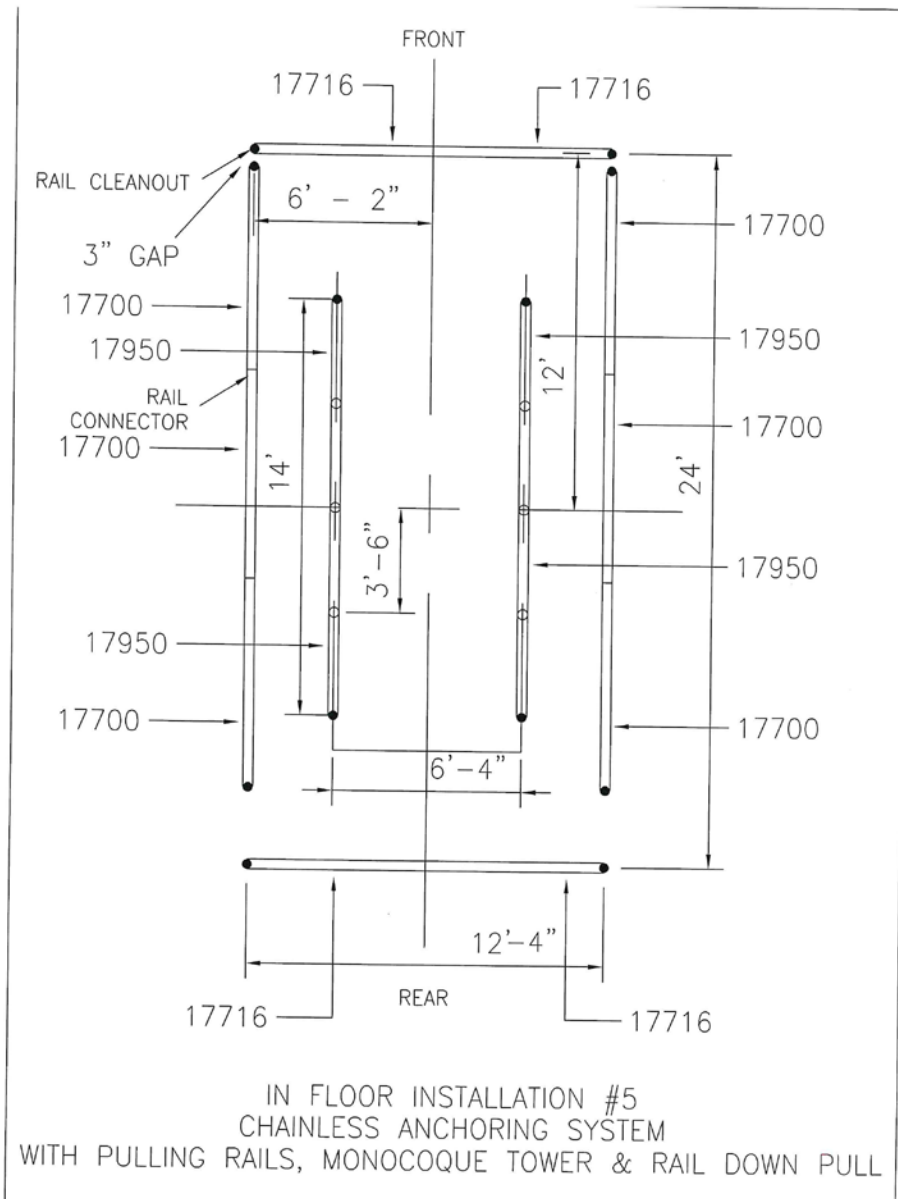

Note: * Minimum width for the Monocoque Pulling Tower only. If using Eze Roller Pulling Towers use a minimum bay width of 14' (4.27 m). Refer to Wedge Clamp Bay Layouts for detailed measurements.



INSTALLATION PROCEDURE FOR FLUSH-MOUNTED RAILS WHEN POURING NEW FLOORS

- 1** At rail endings bolt a Wedge Clamp Rail End Cleanout as shown. For rails with square ends, use the Wedge Clamp Square Rail End Cleanout (Part # 17703); for rails with bevelled ends, use the Wedge Clamp Bevelled End Cleanout (Part # 17902).

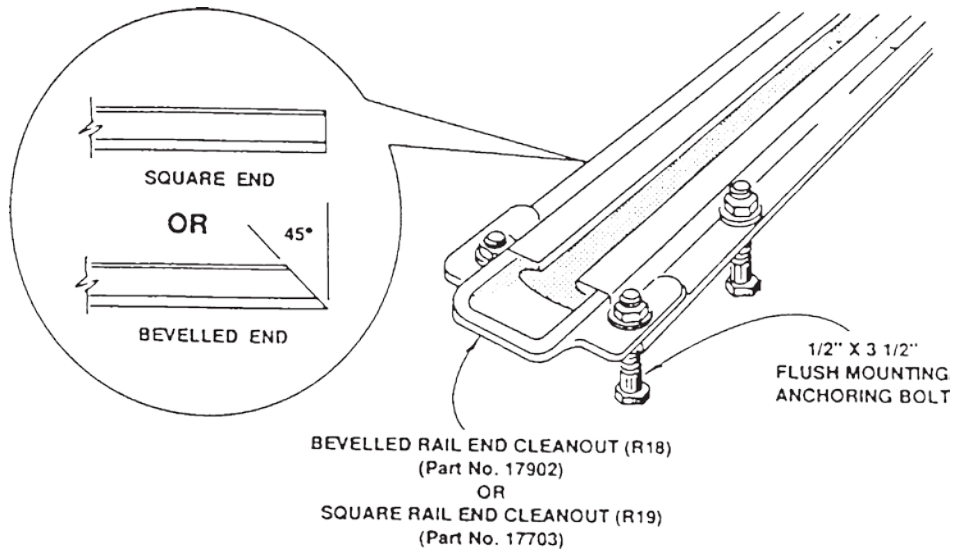

- 2** A qualified construction contractor should be used to prepare the floor area for pouring new concrete. The following instructions are general guidelines for the contractor.

- Plan for a minimum floor slab thickness of 6" (152 mm). Reinforcing wire mesh should be suspended 2" (51 mm) above the bottom of the concrete slab. Sand or gravel is commonly used as a base to pour the concrete on.
- The rails need to be suspended at a level that will allow the top of the rails to be flush with the top of the finished concrete floor. It is important that the rails are held securely to prevent any movement of the rails during the pouring process.
- Position the rails in the desired configuration. Check that the positioning and layout of the rails is correct.

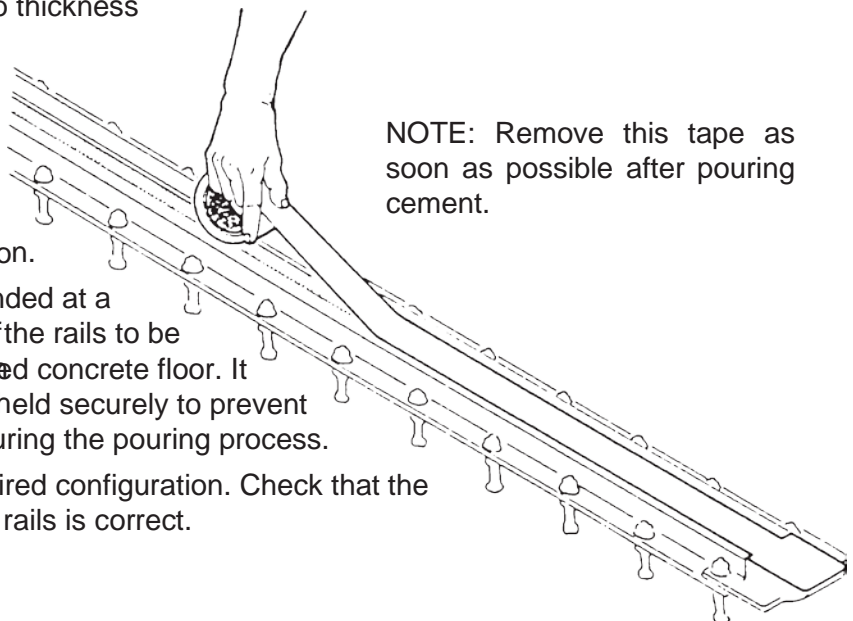



INSTALLATION PROCEDURE FOR FLUSH-MOUNTED RAILS WHEN POURING NEW FLOORS

- 3** The rails need to be suspended at the appropriate height and held securely to prevent movement during the concrete pouring process.

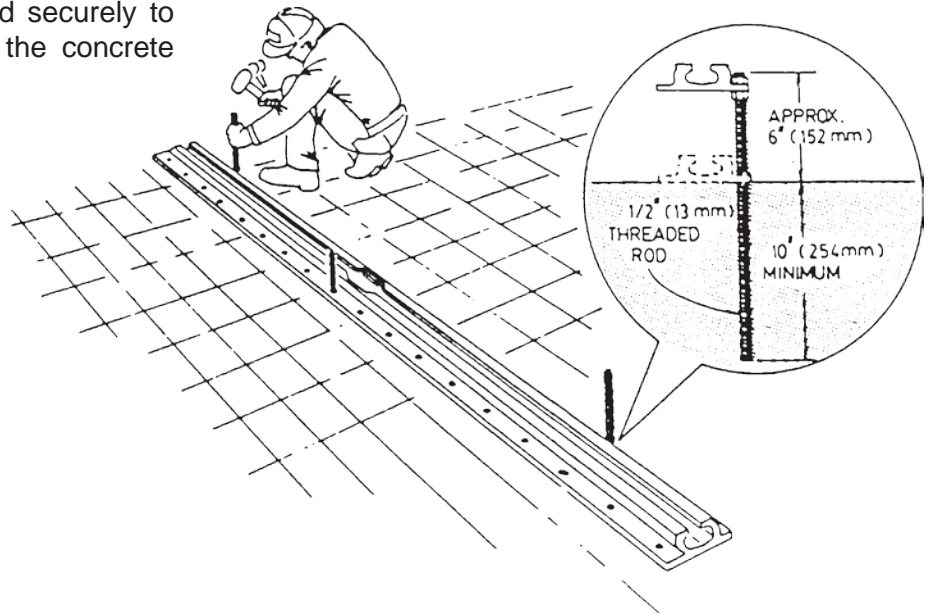

- 4** Check that the rails are held securely at the proper surface height to be flush to the top surface of the concrete. A Rail Connector Plate (Part #17708) should be used between adjoining rails to assure that adjacent rails stay in alignment.

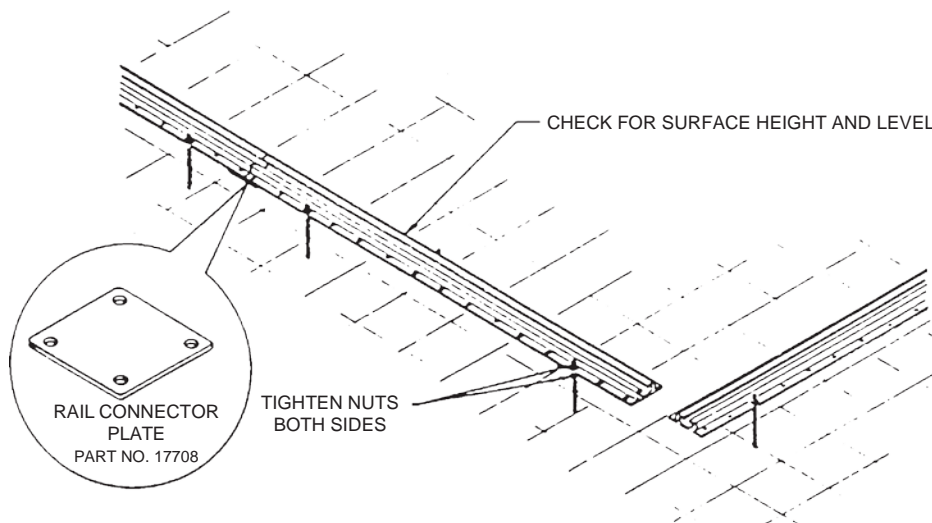



INSTALLATION PROCEDURE FOR FLUSH-MOUNTED RAILS WHEN POURING NEW FLOORS

- 5** Fasten the flush mounting anchor bolts supplied through each hole in the rails as shown. It is recommended to place a heavy layer of tape on the top of the rails to prevent concrete from filling the slots and to keep the rail surface clean.

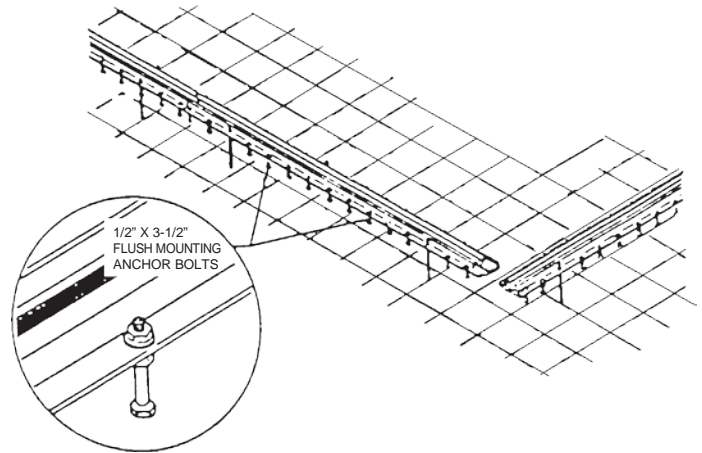

- 6** Suspend the wire mesh approximately 2" (51 mm) above the bottom of the concrete slab.

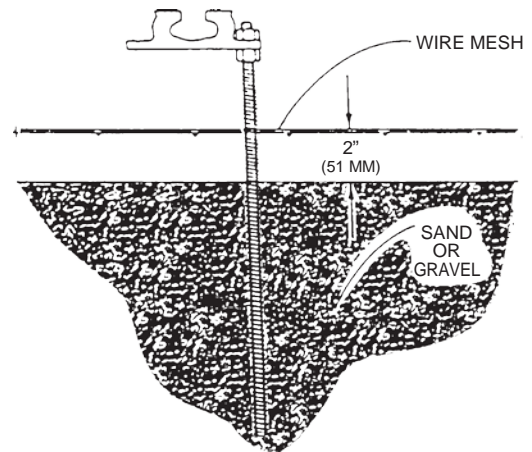

- 7** Allow the concrete to set for 23 days before any pulling is made on the rails. The tape used to cover the top of the rails should be removed within 3 days of the pouring process to prevent hardening of the tape on the rails.

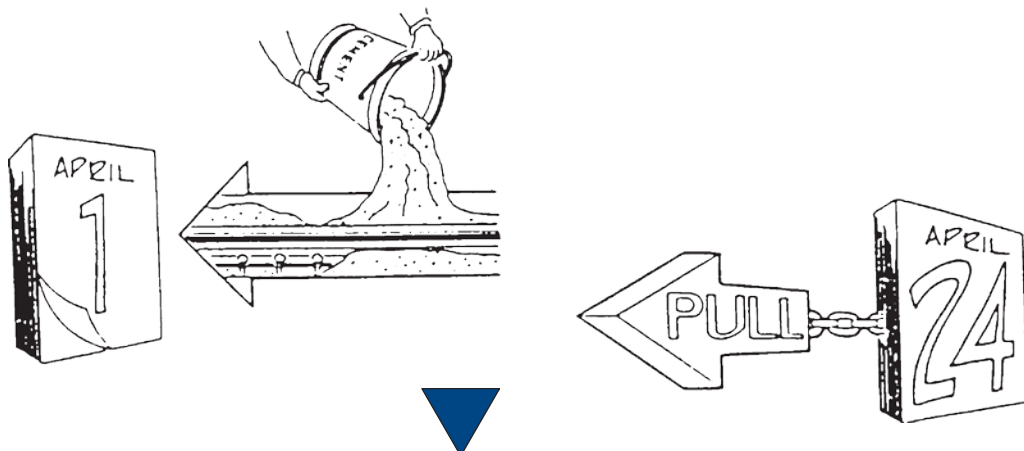



FLUSH-MOUNTING RAILS BY CUTTING INTO EXISTING FLOORS

This section deals with instructions for flush mounting anchoring rails into existing concrete floors. You can use the components shown below from the Wedge Clamp Anchoring System to position the rails properly.

Parts used to position rails when flush-mounting into existing floors

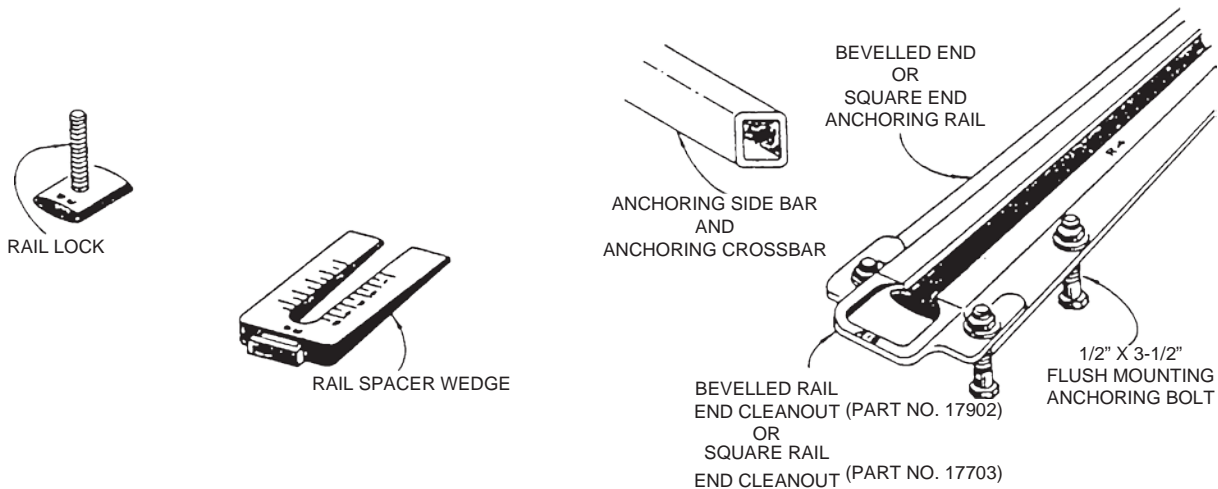

- 1 Draw out where the rails are to be located on the shop floor.
Recheck all of the measurements for accuracy and square.

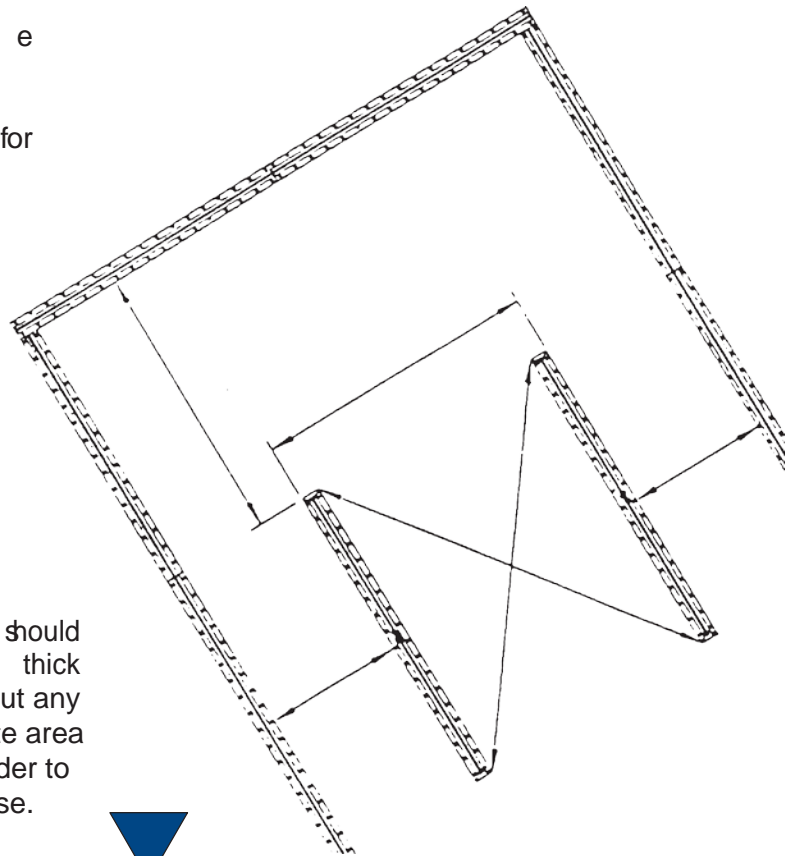

WARNING: The concrete floor should be a minimum of 6" (152 mm) thick and be in good condition without any sign of cracking in the immediate area of the anchoring rails in order to provide a proper anchoring base.





FLUSH-MOUNTED RAILS BY CUTTING INTO EXISTING FLOORS

2 Cut a channel in the concrete floor. A concrete cutting saw is commonly used for this purpose. The channel should be a minimum of 12" (305 mm) wide.



WARNING: Pipes, heating elements, or electrical wires may be contained in or under the concrete slab. Damage to such in-floor installations can result from drilling or cutting into the floor. Serious injury or death can result from the drill bit or floor rail contacting electrical wires that may be under the floor surface.

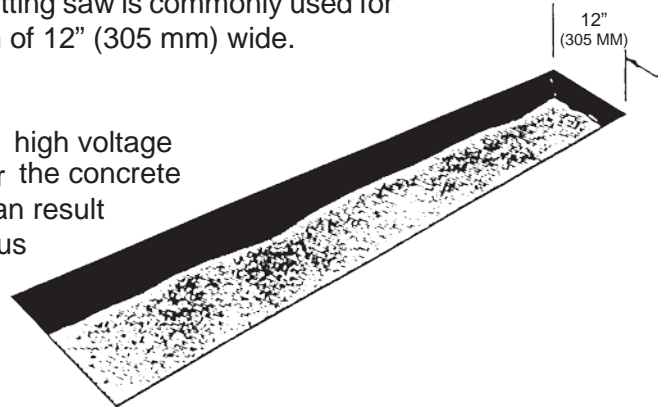

3 Assemble the rail end caps on the aluminum rails and attach the holding bolts (1/2" diameter x 3-1/2" long) with two nuts.

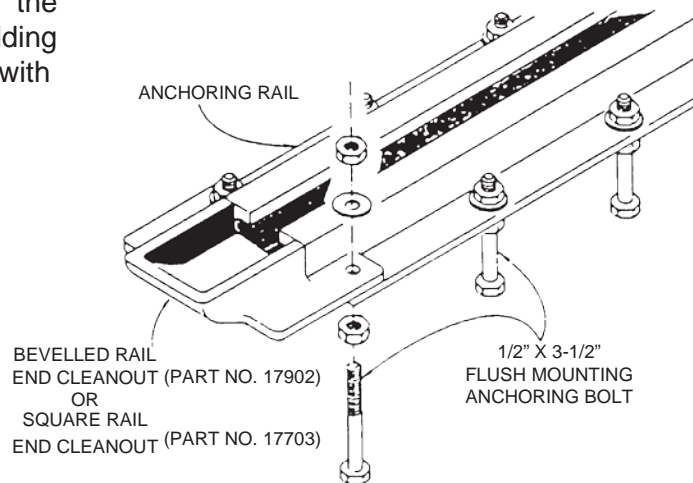

4 With four Wedge Clamp rail locks (Part #17604) and the four 2" x 2" (51mm x 51mm) steel anchoring bars, locate and adjust the two rails to the appropriate spacing and height.

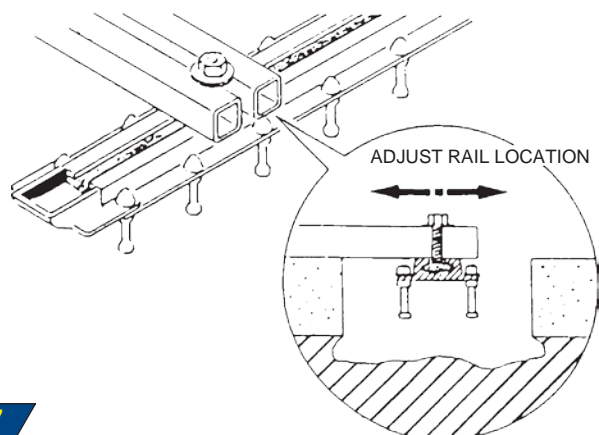



FLUSH-MOUNTED RAILS BY CUTTING INTO EXISTING FLOORS

- 5** Use the Wedge Clamp spacer wedge (Part #17605) under the bars for height adjustment. Tighten the nut on the rail locks to be sure that the rails do not move against the steel anchoring bars.

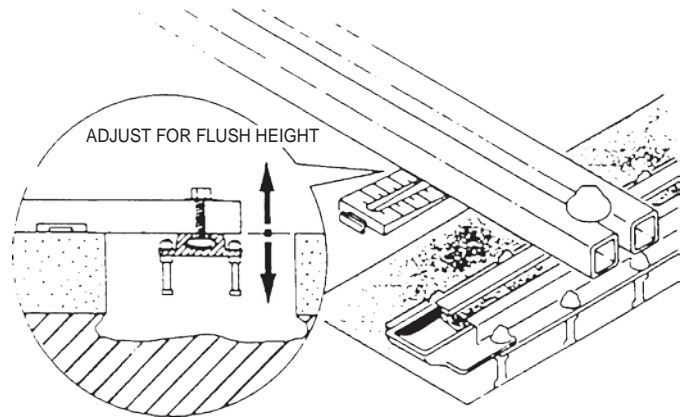

- 6** It is important that forward and rearward sets of steel anchoring bars are flat relative to each other. Using a carpenter's level you can determine if the bars are level with each other.

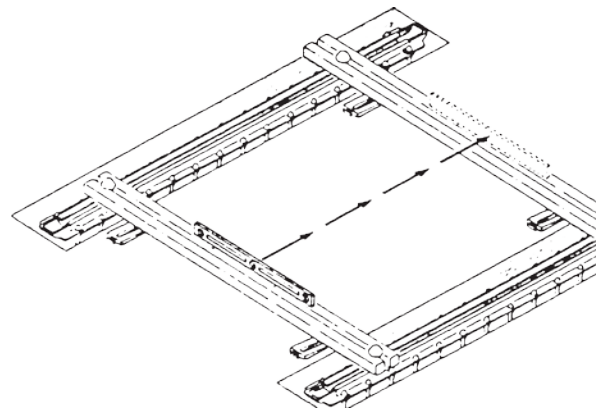

- 7** Be sure that the steel anchoring bars do not move during the concrete pouring process. It is advisable to place masking tape over the slots in the rails to prevent any concrete from falling into the slots during the pouring process. Remove the tape within three days of the concrete pouring to prevent the tape from hardening onto the rails.

Allow the concrete to set for three days before removing the steel bars. Pulling can be made on the rails after the concrete sets for 23 days.

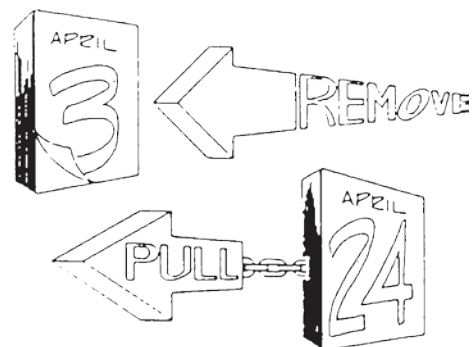
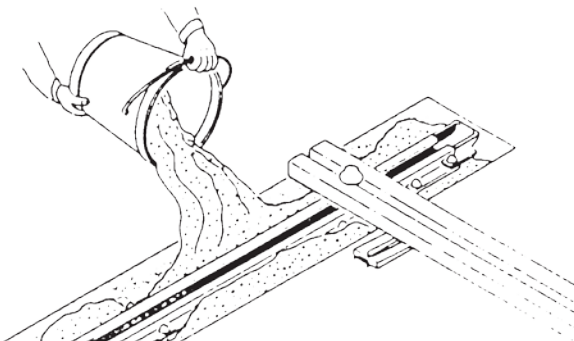



SURFACE MOUNTING RAILS ONTO EXISTING FLOORS

1

Draw out where the rails are to be located on the shop floor.

Recheck all of the measurements for accuracy and square.



WARNING: The concrete floor should be a minimum of 6" (152 mm) thick and be in good condition without any sign of cracking in the immediate area of the anchoring rails in order to provide a proper anchoring base.

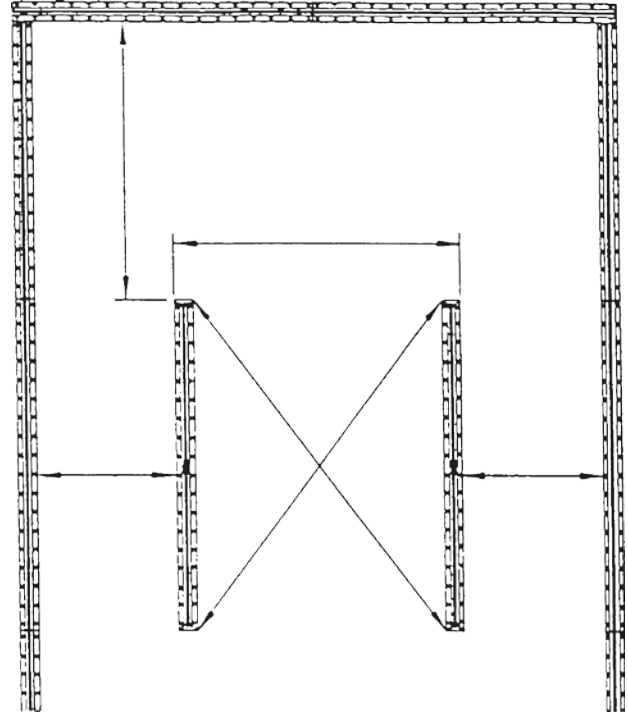

2

Use the rail as a template and drill a hole at each end of the rail on opposite sides of the rail. Insert an anchor bolt in each hole and tighten to hold the rail in position. Keep the drill straight while boring the holes.

It is better to drill deeper than too shallow.



WARNING: Pipes, heating elements, or high voltage electrical wires may be contained in or under the concrete slab. Damage to such in-floor installations can result from drilling or cutting into the floor. Serious injury or death can result from the drill bit or parts of the floor rail contacting electrical wires that may be under the floor surface.

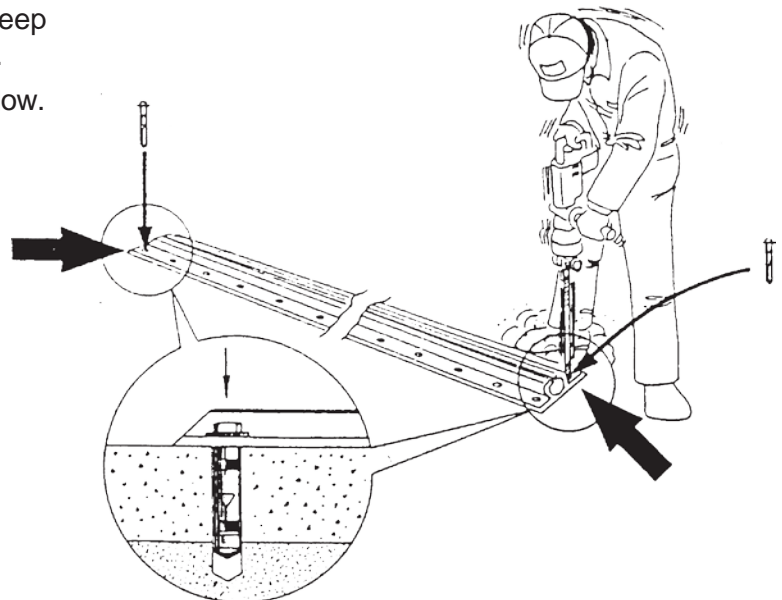



SURFACE MOUNTING RAILS ONTO EXISTING FLOORS

3

Keeping the drill straight, drill the remaining holes

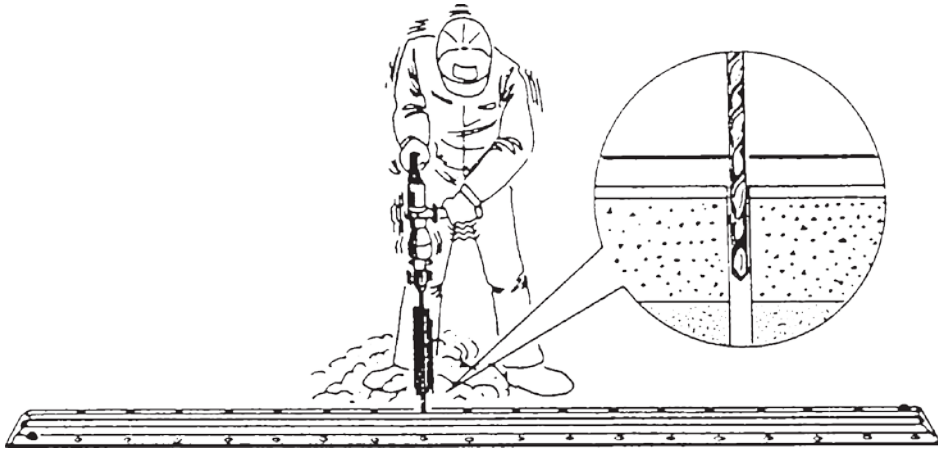

4

Insert the bolts into the holes and tighten to a torque of 60 ft. lbs.

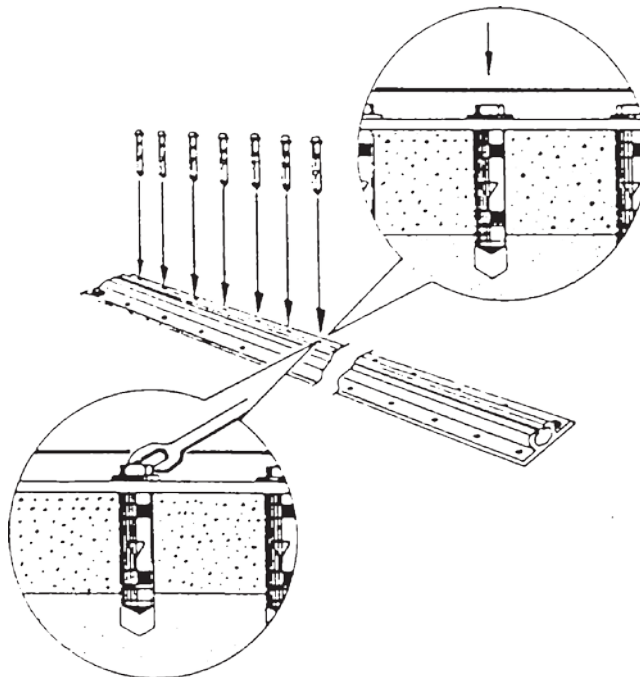



Wedge Clamp is a Trademark of 668201 BC Ltd

Wedge Clamp's management welcomes your comments and suggestions on any of our products. We are committed to developing longstanding relationships with our customers, therefore, your input is invaluable and will help us improve and develop the best possible products. Please feel free to contact us with any comments and/or suggestions at the address below. We thank you for choosing the Wedge Clamp System.

WEDGE CLAMP SYSTEMS INC.
170 - 21320 Gordon Way
Richmond, B.C. V6W 1J8 CANADA

Toll Free Factory Support: . . 1-800-615-9949
Tel: (604) 207-9595
Fax: (604) 207-9593