

LENGTH AND HEIGHT ACCESSORY USER INSTRUCTIONS

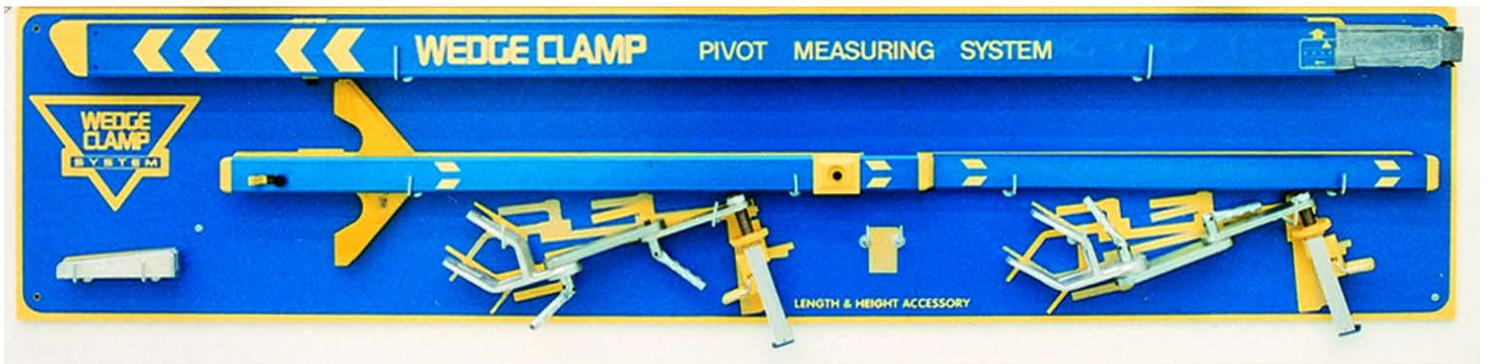

Wedge Clamp Systems Inc. 170-21320 Gordon Way, Richmond, BC V6W 1J8
Tel: (604) 207-9595 | Fax: (604) 207-9593 | Toll Free: 1-800-615-9949

INTRODUCTION

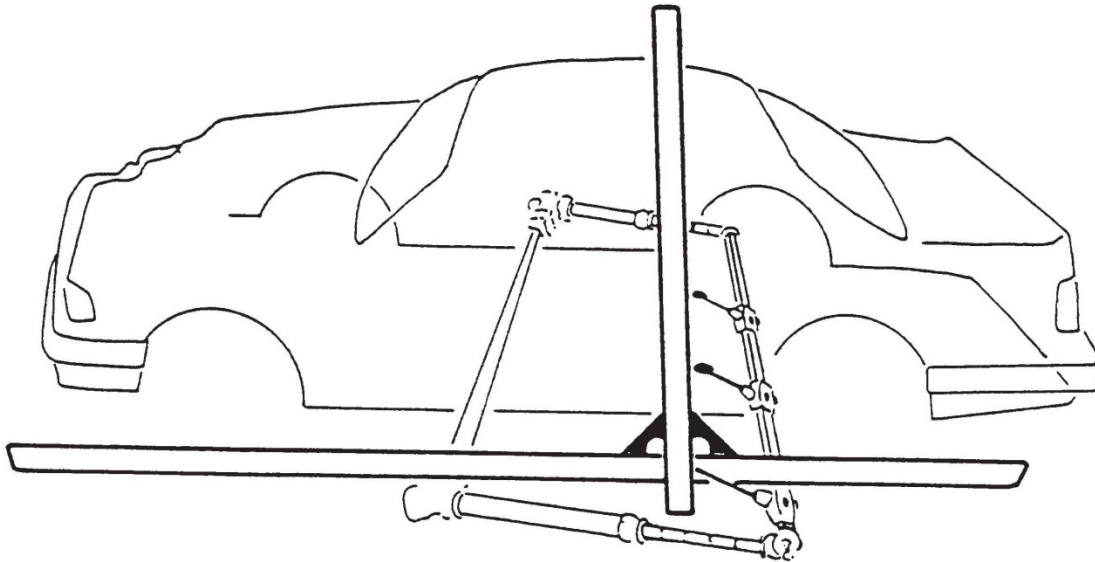

The Wedge Clamp Length and Height Accessory works with the Wedge Clamp Pivot Measuring System to provide three dimensional readings of length, width, and height above datum plane for any point on the vehicle.

The Length and Height Accessory can be mounted to either the Wedge Clamp Anchoring System or the Wedge Clamp Pivot Mounting Kit.

The pointers of the Wedge Clamp Pivot Measuring System always work from and indicate the vehicle centerline and horizontal datum plane. The third pointer on the measuring crossbar transfers control point dimensions to the outside of the vehicle where length and height readings are made on the Length Bar and Height Bar of the Length and Height Accessory. The Length and Height Accessory is calibrated to correspond precisely with any vehicle's datum plane. Both symmetrical and asymmetrical control points can be established in three dimensions with the Length and Height Accessory working in conjunction with the Pivot Measuring System.

COMPONENTS

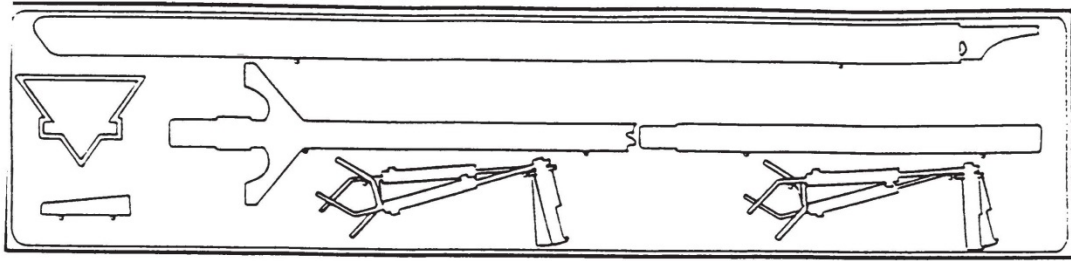

Length & Height Accessory Tool Board

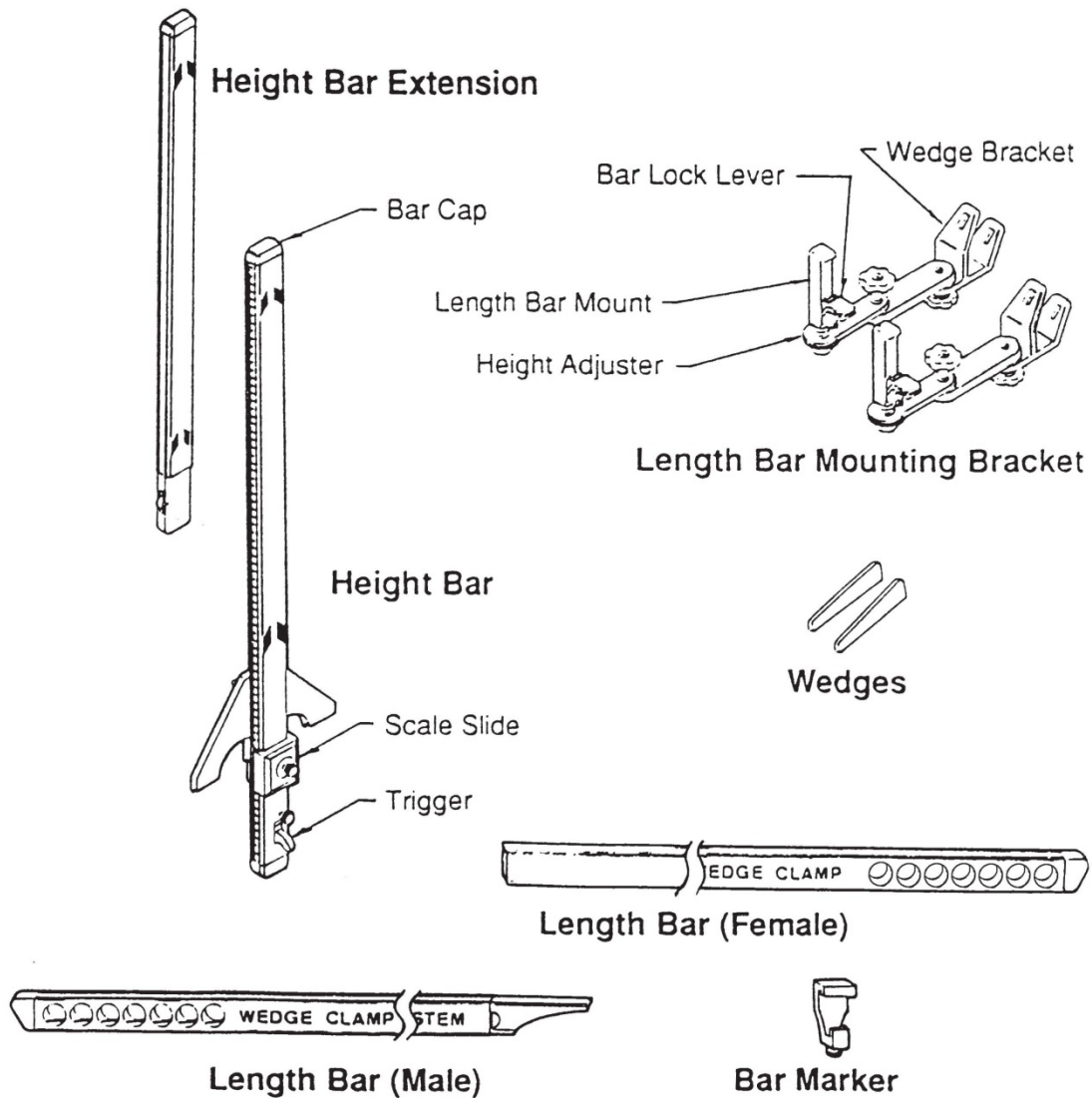

SET UP PROCEDURE

- 1** Start by mounting the Pivot Measuring System on the vehicle and use the shortest set of side extension tubes. Set up the Pivot Measuring System so that two pointers reference a set of control points away from the damaged area. These control points will become your "0" control points for the purpose of length measuring. Set the third outside pointer at 93 cm on the undamaged side of the vehicle as shown.

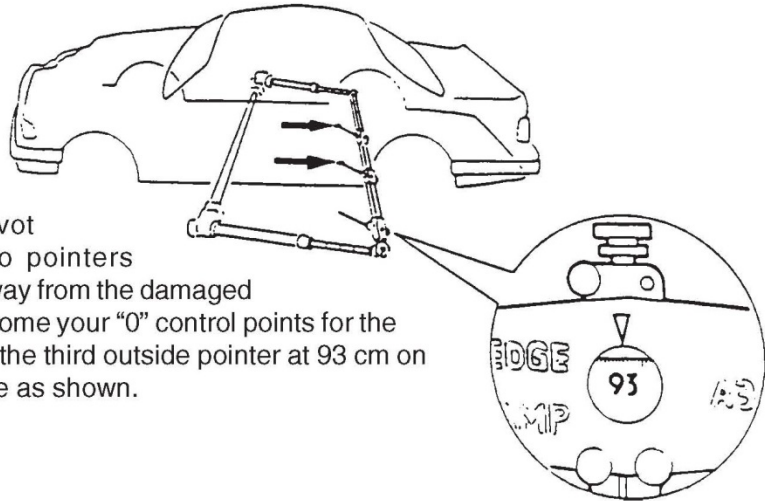

- 2** Install the first length bar mounting bracket onto the Pivot Mounting Kit or Wedge Clamp Anchoring System as shown below. Hammer the wedge through the wedge bracket firmly. Note that the wedge bracket is attached to the mounting bracket differently for the Pivot Mounting Kit than for the Wedge Clamp Anchoring System. The wedge bracket can be removed and remounted by undoing the threaded knob.

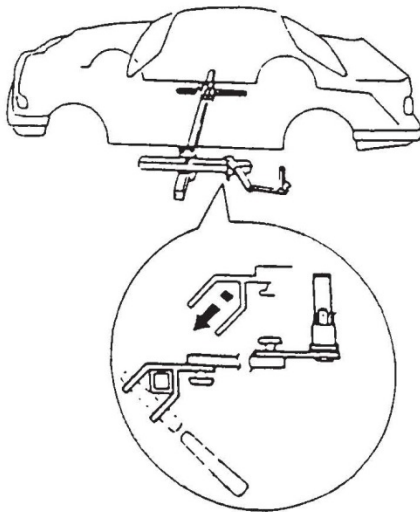

PIVOT MOUNTING KIT

OR

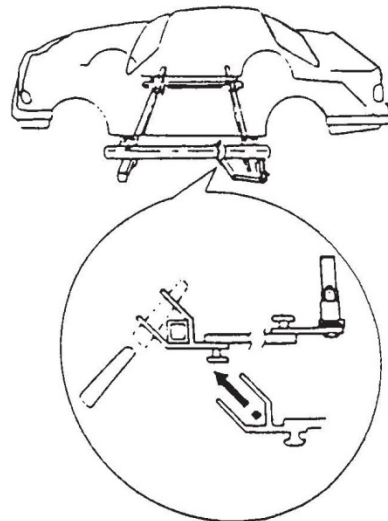

WEDGE CLAMP ANCHORING SYSTEM

SET UP PROCEDURE

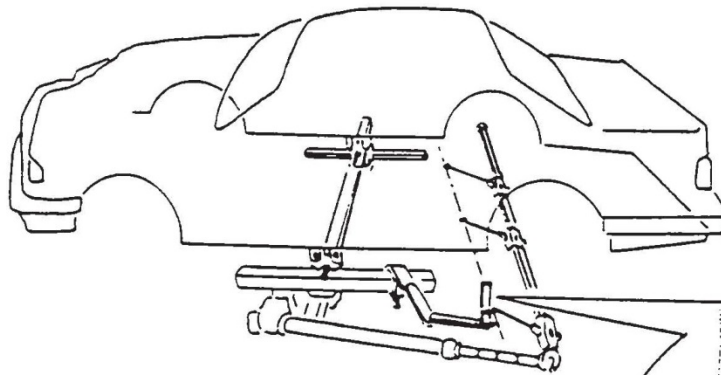

- 3** Set the first mounting bracket so that the Length Bar Mount is in line with your "0" control point as shown. Rotate the height adjuster so that the top of the bar mount is just below the bottom edge of the doors.

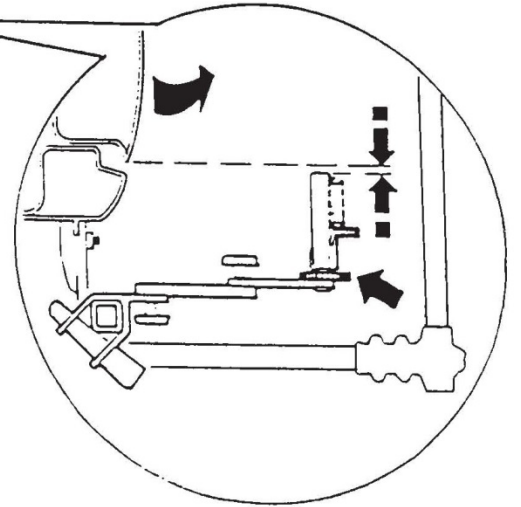

- 4** Position the bracket arms so that the outer edge of the Bar Lock Lever is in line with the outside third pointer set at 93 cm as shown. Tighten the knobs on the bracket arms.

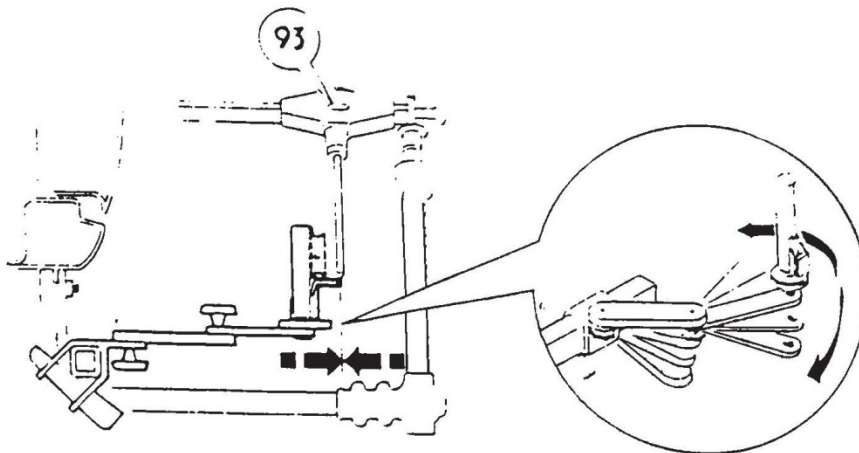

SET UP PROCEDURE

- 5** Install the second length bar mounting bracket as shown below. Position the arms on this bracket so that the Bar Mount is approximately the same distance from the car body.

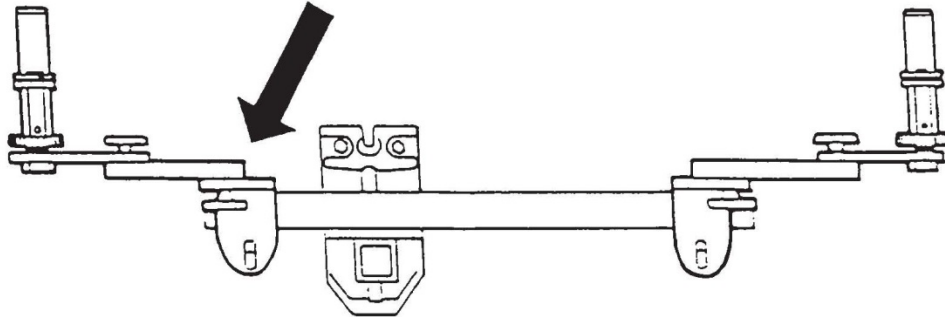

- 6** Connect the male length bar to the female length bar as shown.

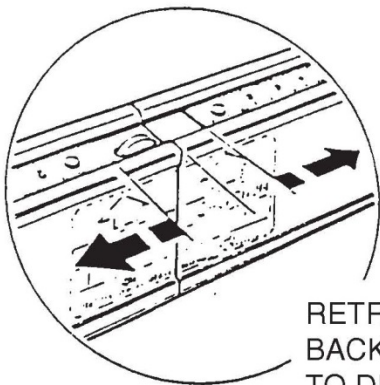
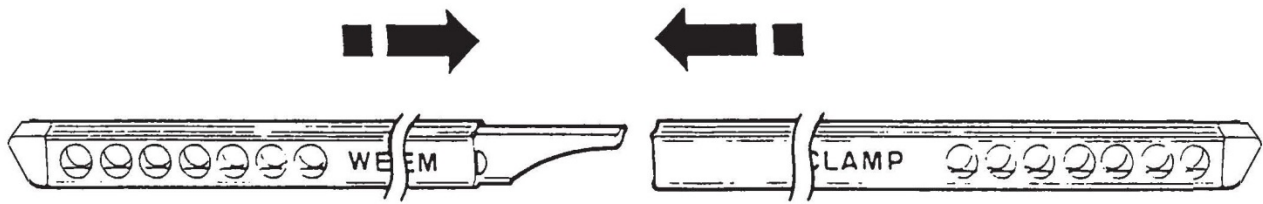

! CAUTION: To disconnect the bars, slide scales back onto each of the bars.

RETRACT SCALES
BACK FROM JOINT
TO DISCONNECT BARS

SET UP PROCEDURE

- 7** Instal the assembled length bar onto the mounting brackets. Be sure the decals always face outwards as shown.

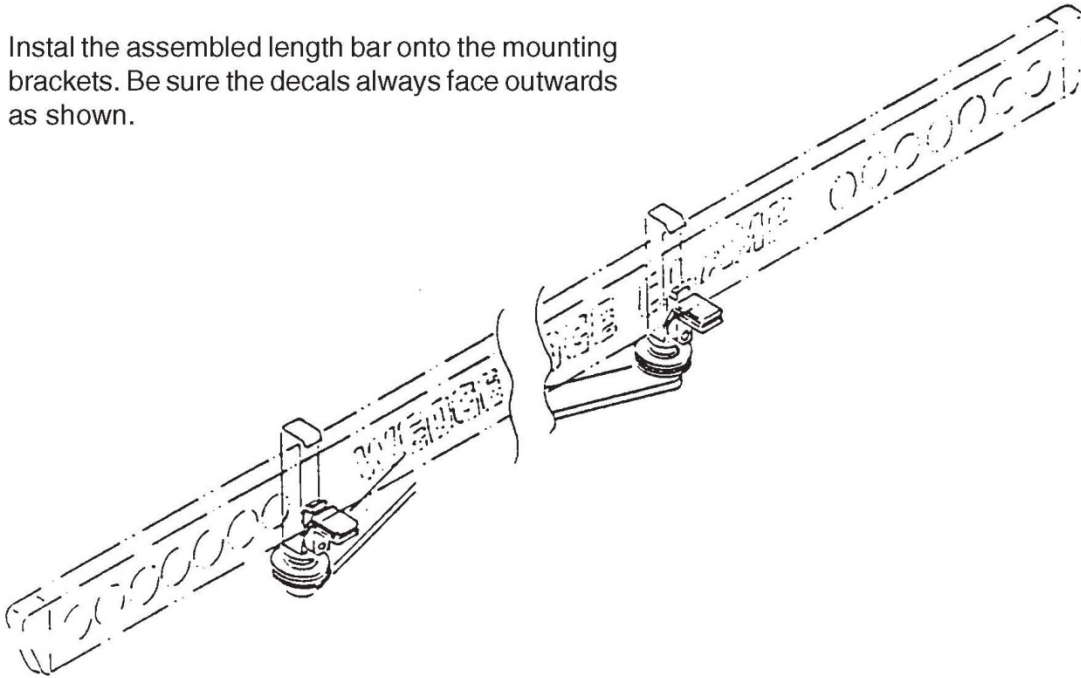

- 8** Position the length bar on the mounting brackets so that the end of the bar aligns with the extreme damaged end of the vehicle as shown.

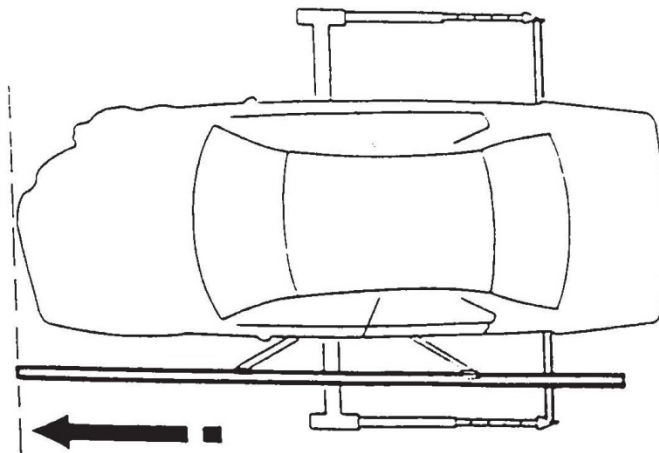

SET UP PROCEDURE

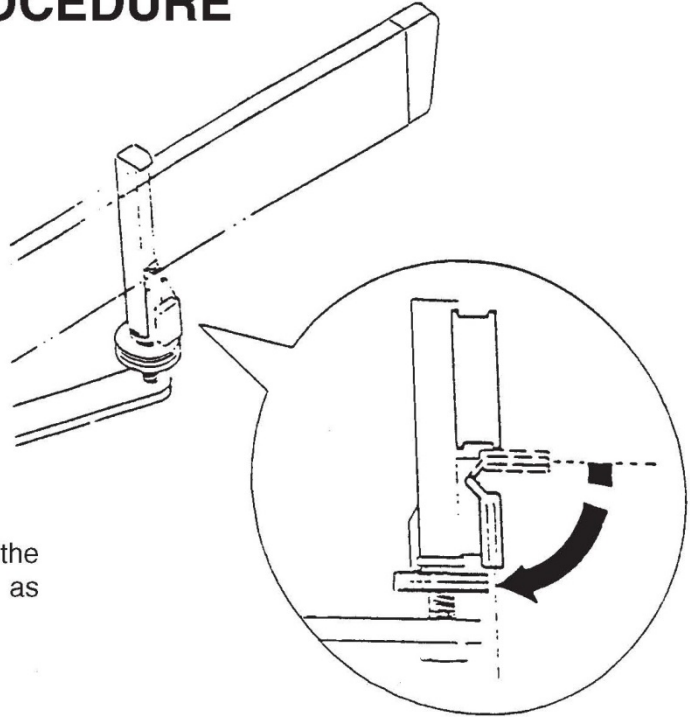

- 9** Lock the length bar in place by moving the levers on the mounting brackets down as shown.

- 10** If measurements are required at heights greater than the top of the height bar, then the height bar extension must be used. To connect the height bar extension move the scale slide to the very bottom of the height bar as shown and remove the cap from the height bar. Insert the height bar extension into the top of the height bar.

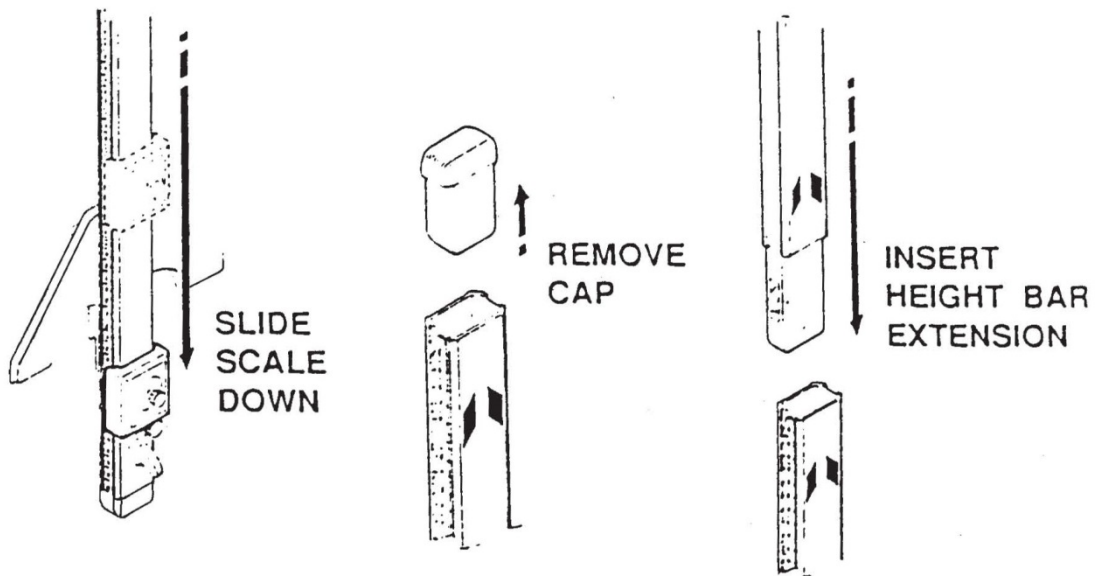

SET UP PROCEDURE

- 11** Install the height bar onto the length bar near the original control points ("0" point).

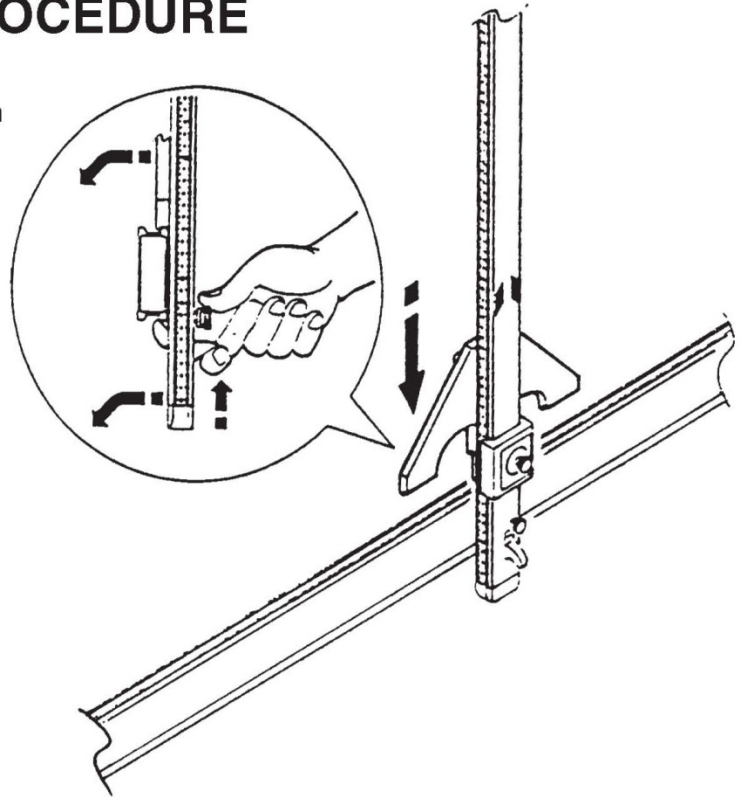

- 12** Be sure that the pointers under the vehicle are still properly positioned to reference your "0" control points. Move the height bar so that the scale touches the third pointer as shown.

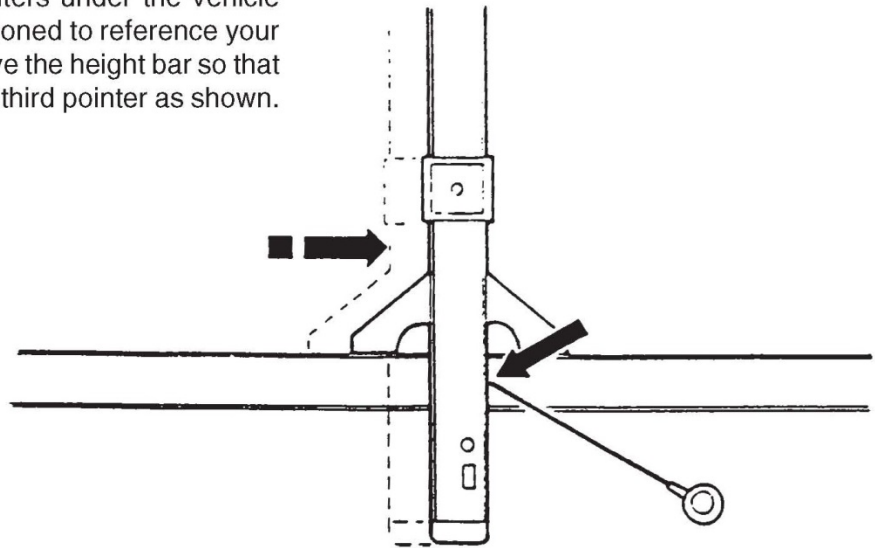

SET UP PROCEDURE

13 Read the datum height given for your “0” control point from the dimension manual and move the scale slide on the height bar so that this same reading is reproduced at the tip of the third pointer.

This sets the height scale for datum height measurements. Lock the scale slide by tightening the thumbscrew. The scale slide now remains in this position for the remainder of the repair.

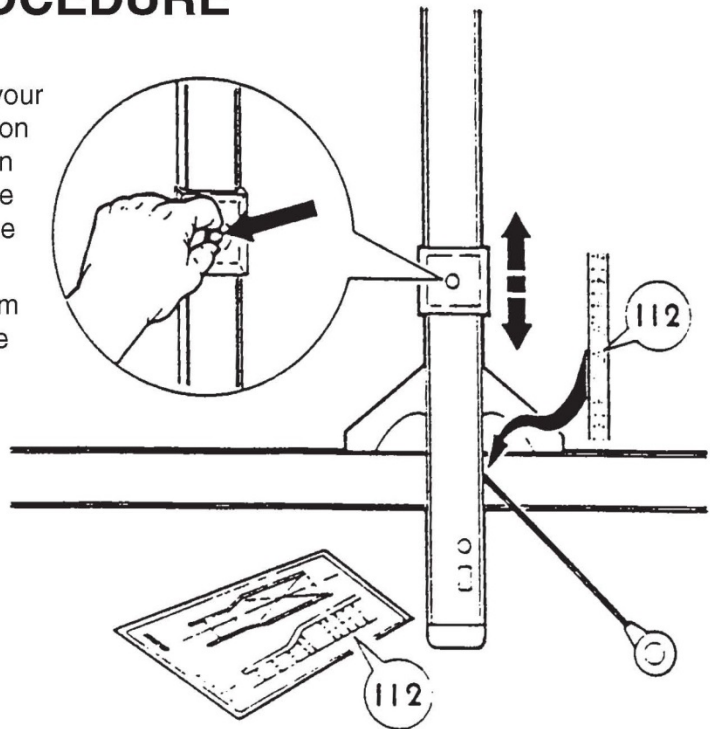

14 Slide both scales on the length bar so that the “0” on the scales align with the inside edge of the yellow plastic support on the same side of the height bar that the pointer is touching (see diagram).

This sets your length scale for datum length measurements.

Note that length dimensions are always read from the side of the height bar that the pointer is indicating to.

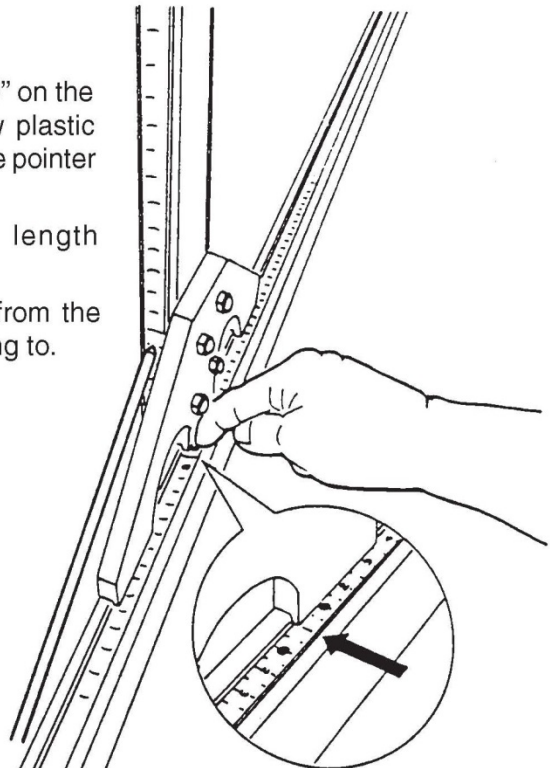

SET UP PROCEDURE

- 15** The bar marker allows the length bar to be moved and returned to the same location. Slide the bar marker so that it contacts the mounting bracket as shown. The marker should be positioned on the side of the mounting bracket to which the bar will be moved. Tighten the thumbscrew on the bar marker.

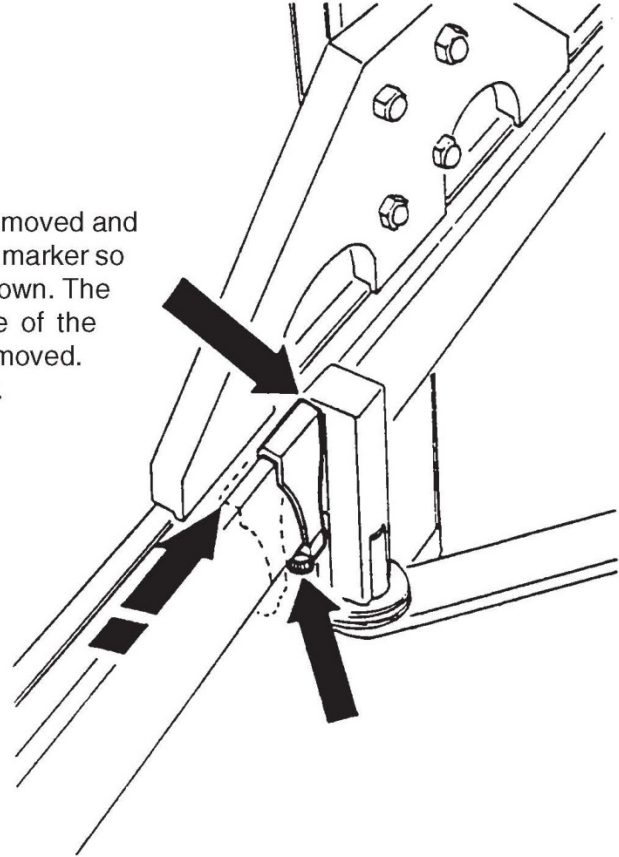

- 16** Rotate the pivot system so that the pointers now reference a set of control points some distance from your "0" control points. It is important that the control points you choose have not suffered any significant damage from the accident. Slide the height bar along the length bar so that the scale contacts the third pointer.

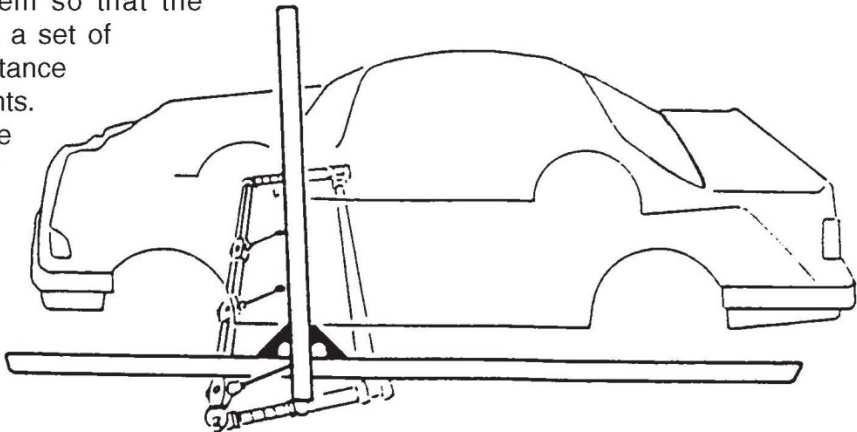

SET UP PROCEDURE

- 17** Note the datum height of these new control points from your dimension manual and turn the height adjuster on the nearest mount so that the correct datum height reading on the height bar comes into contact with the third pointer. You are now ready to make datum height and length measurements anywhere on the vehicle.

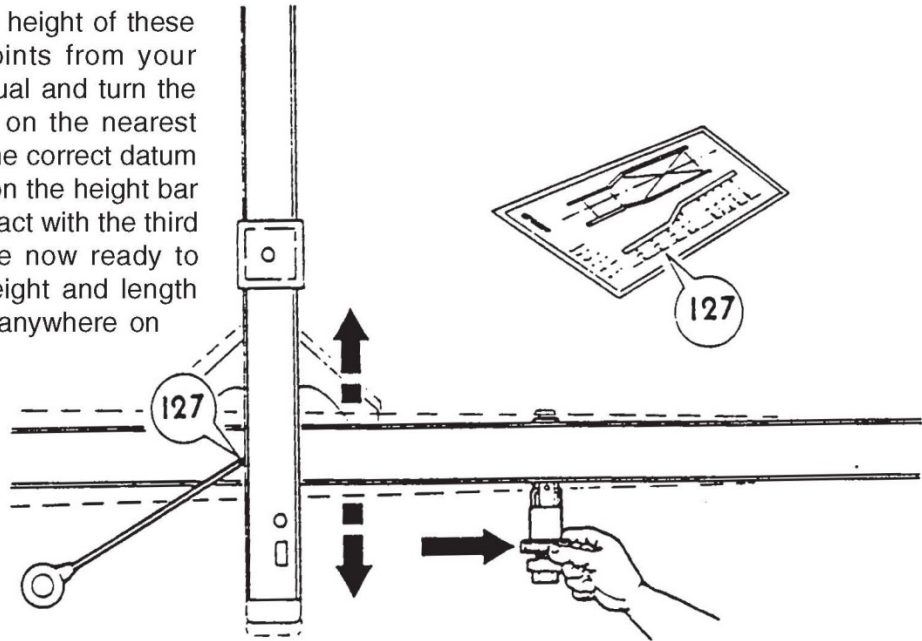

- 18** To check reference points anywhere on the vehicle:

- position the height bar on the length bar at the desired length reading;
- position the pivot measuring system so that the third pointer touches the desired datum height reading on the height bar.
- Set the inner two pointers to the appropriate width.

The pointer ends will now indicate the proper width, length, and height of the desired reference point.

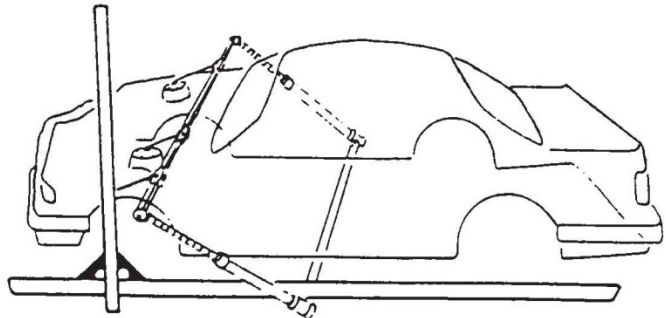
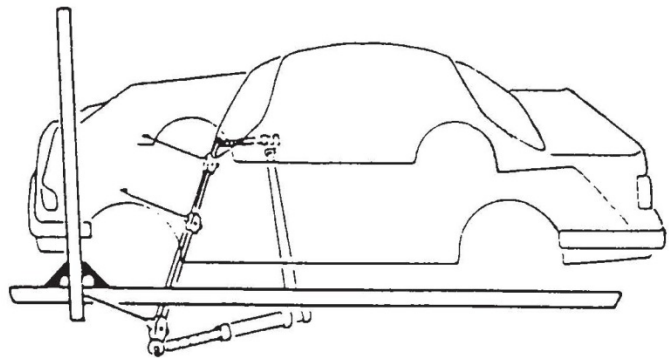

SET UP PROCEDURE

- 19** If you wish to move the length bar clear of the working area:
- check that the bar marker is locked on the length bar so that the bar can be returned to its original position.
 - raise the bar lock levers on the mounting brackets and slide the length bar away;
 - you may then reposition the length bar by sliding the bar back to the original position (where the bar marker touches the rear mounting bracket) and lowering the two bar lock levers.

