

# FULL FRAME ANCHORING SYSTEM

**Introduction .....1**  
**Setting up the Full Frame Anchoring System .....4**  
**Anchoring procedures using the: .....6**  
    Box Frame and C Section Adapter.....  
    Leaf Spring Adapter.....  
    Torsion Bar Adapter.....  
    Frame Hole Adapter.....  
**Removing Vehicle from the Full Frame Anchoring System.....10**  
**Parts Diagram and Listing.....11**



Figure 1: FFAS with Mounted Frame

Wedge Clamp Systems Inc. 170-21320 Gordon Way, Richmond, BC V6W 1J8  
Tel: (604) 207-9595 | Fax: (604) 207-9593 | Toll Free: 1-800-615-9949

## INTRODUCTION

This manual explains how to mount a Truck or SUV on the Wedge Clamp Full Frame Anchor System (FFAS). The FFAS is designed to let you anchor a Full Frame Vehicle as an independent floor system, or to a Wedge Clamp Chainless floor anchoring system; allowing you to make multiple pulls without changing the anchoring attachments and without damaging the vehicle in the pulling process.

An important component of the Wedge Clamp FFAS is the patented Universal 2-Axis Swivel Base Assembly (Figure 2). This clamping system is designed to anchor the full frame vehicle regardless of the type of frame (Box or C-Section) and, or, the curvature of the frame rail itself. The Leaf Spring, Torsion Bar and Jig Hole adapters provide the versatility of the type of clamp procedure needed for different vehicles.



Figure 2: Close-Up of Swivel Base Assembly



**WARNING:** Serious damage or injury can occur if a vehicle is not anchored securely for pulling. It is your responsibility to evaluate the vehicle and to determine the safest anchoring method. Always check the anchoring points during pulling to be sure that the vehicle remains securely anchored.

The Full Frame Anchoring System consists of the following components:

Quantity	Description	Part #
2	Anchoring Crossbeams	92860
4	Swivel Clamp Assembly	92880
1	Anchoring side bar - 7' (1.83 m)	17100A
12	Steel wedge	20060
4	Chainless R7 anchoring stand	17600
4	Anchoring rail, beveled & slotted	

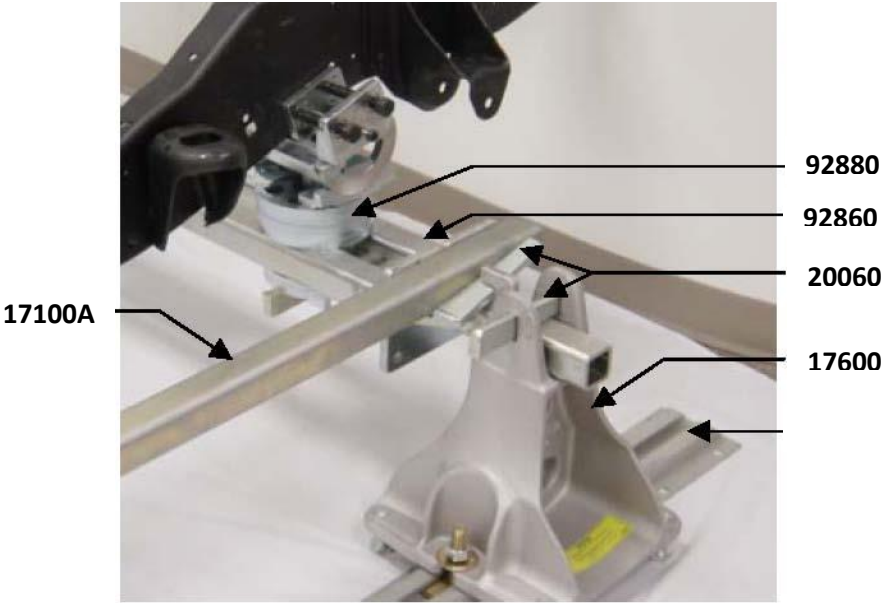

Figure 3: Parts

## Setting Up the Full Frame Anchoring System

**An overview of the steps needed to mount a vehicle on the full frame anchoring system:**

- Fasten the desired adapter to the Swivel Base Clamp (#92881)
- After raising vehicle and placing on safety stands, install complete clamp to the frame
- Slip Pull Down Bar (#92900) into bottom of the Swivel Base Clamp
- Using a floor jack, line up Anchoring Crossbeams (#92860) underneath Pull Down bars, then lower onto R7 Anchoring Stands (#17600)
- Position the Swivel Base Plate (#92980) and the C- Spacers (#92910) for the required height, onto Anchoring Crossbeams
- Slide the Full Spacer (#92911) onto the Pull Down Bar, and hold in place by slipping a Wedge (#20060) into the bottom of the Pull Down Bar
- Place remaining C- Spacers above the Full Spacer
- Install the side anchoring bars (#17102)
- Lock all anchoring bars to the stands using steel wedges
- Tighten the R7 Anchoring Stands to the rails (#17900)

### Tools Required:

1. Floor jack
2. Safety stands
3. Air wrench or Hand Ratchet
4. Sockets, 17mm,24mm
5. 8mm allen head wrench or socket
6. Hammer (3 lbs or 1.5 kg)
7. Open or box end wrench - 1 <sup>1</sup>/<sub>8</sub>" (29 mm)

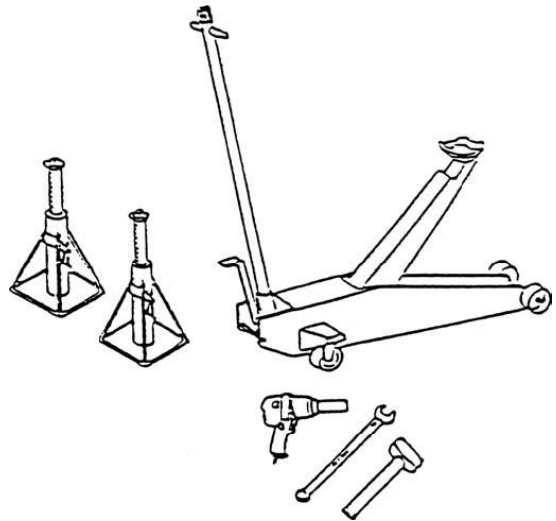

### Set Up Procedure:

1. When setting up the Full Frame Anchoring System, it is important that you check for uneven floor conditions. Do this by positioning the anchor stands over the floor rails, approximately where they would normally be used when anchoring the vehicle.
2. Adjust the leveling bolts at the bottom of the anchoring stands until about two threads (5 mm) are showing on the topside of the stand base. (If you are using anchoring rails, which are flush-mounted into the concrete, then thread in the bolts on the anchoring stands from the top of the stand. Turn them into the thread holes until about two threads are protruding from the bottom side of the stand base.)
3. Place the two anchoring crossbars (6'4", or 1.93 m long) between each left and right hand pair of anchoring stands.
4. You can determine uneven floor conditions by standing at one end of the repair bay and sighting across the two anchoring crossbars to determine if the two bars are parallel to each other. Adjust the bolts at the bottom of the lower anchoring stand(s) until both the front and rear-anchoring crossbars are running parallel to each other.

If you find that a significant adjustment was required to make the two crossbars parallel then you should remember which R7 Anchoring Stand goes at each end of the anchoring rails to maintain the bolt adjustment you have made for future anchoring setups. In any event, it is useful to check that the crossbars are parallel by sighting along the bars after completing each anchoring setup on the vehicle. Re-adjust the bolts on the stands to make the crossbars parallel if necessary.

**1. Install the desired adapter to the Swivel Base Clamp (#92881) using the four Flathead Cap screws (# 92888) measuring M12x30mm.**

- a) Centre vehicle between the left and right anchoring rails.
- b) Raise the front end of the vehicle and place the safety stands underneath.

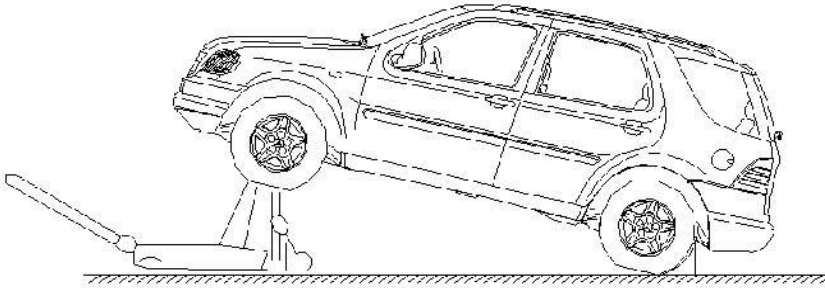

- c) Tighten complete Swivel Clamp Assembly (#92880) to the desired position on the full frame and repeat procedure on the opposite side. Do not clamp onto fuel or brake lines and other obstructions along the frame rail area. **Note**, make sure tightening bolts are easily accessible for use with air wrench, hand ratchet and 16mm socket or a 16mm wrench.
- d) Make sure clamps are evenly spaced on the rail from one end to the other.
- e) Slide the Pull Down Bar (#92900) into the half-moon opening at bottom of the Swivel Base Clamp (#92881).
- f) Repeat on opposite side.

**2. Install the Anchoring Crossbeams (#92860).**

- a) Using a floor jack,(with centre saddle removed), place the centre pin of the 76" (1.94 m) Anchoring Crossbeam (#92860) into the saddle pin hole of the jack, then slide Anchoring Crossbeam into position directly underneath the now hanging Pull Down Bars. Position Swivel Base Plate and the C-Spacers, for required height, on top of the Anchoring Crossbeam
- b) Raise the Anchoring Crossbeams so that the Swivel Base Plate is in contact with the Swivel Base
- c) Slide the Full Spacer (#92911) through the bottom of the Pull Down Bar and insert a Wedge (#20060) to hold the Full Spacer in place, then slide the remaining C-Spacers onto the Pull Down Bar on top of the Full Spacer.
- d) Lift vehicle to remove the safety stands. Relocate jack underneath vehicle crossbeam. Do not use crossbeam to lift vehicle. Lift and remove safety stands. Repeat for rear.

**e)** Position the R7 Anchoring Stands with the Anchoring Crossbeams and lower into position. Using a 3lb hammer, drive the wedge into place to secure the Swivel Clamp Assembly.

**Note:** There are 6 C-Spacers and 1 Full Spacer for every Swivel Clamp Assembly. These C-Spacers can be used above or below the Anchoring Crossbeam to gain or reduce mounting height or to level the vehicle. Staggering them above or below the Anchoring Crossbeam does this, but you must always use all of the spacers allocated for each clamp.

### 3. Install R7 Anchoring Stands:

**a)** Always position the R7 Anchoring Stands so that the bolt adjustment is correct to counteract for any uneven floor conditions as described.

**b)** Insert the rail locks into the anchoring rails and into the short slots in the base of the Anchoring Stands to align stands with the anchoring rails. Do not insert the rail spacer wedges beneath the Anchoring Stand yet.

**c)** Install the 6' (1.83 m) anchoring sidebars between the front and rear Anchoring Stands on either side. These bars should drop in easily between the clamp body and the anchoring side bar retainer button on the clamp flange. If the bars do not drop in easily the swivel clamps may not be aligned properly and need to be adjusted.

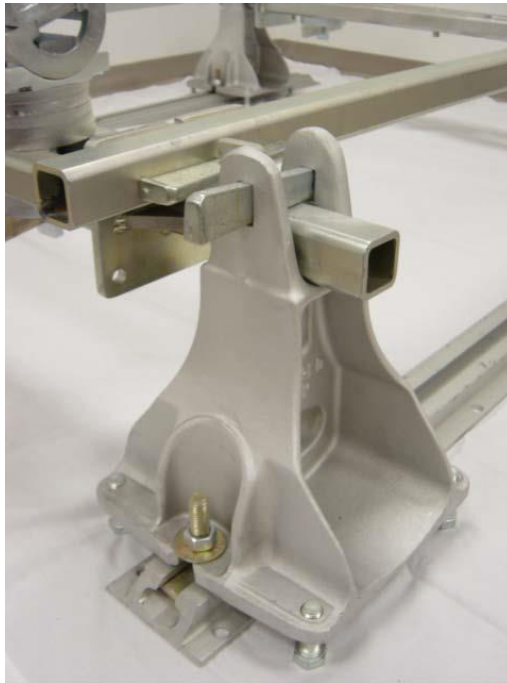

Figure 4: Anchoring Stand

**4. Hammer wedges firmly into place through the tops of the mounting stands.**

Remember that the flat side of the wedge always goes against the bar.

**5. Install wedges (facing opposite the pulling force ) along side the cross bars and hammer in firmly.**



**6. CAUTION:** Before disassembling the anchoring system you must first remove the wedges at the top of the anchoring stands, otherwise sill damage will occur.

**7. Insert the rail spacer wedges between the anchor stands and the floor rail –**

Insert by hand until snug and then tighten rail lock nuts firmly with  $1\frac{1}{8}$ " (29 mm) wrench.



**Figure 5: Anchoring Stand with Parts**

**The vehicle is now anchored and you are ready for pulling.**



**To remove vehicle from the anchoring system, reverse the set up procedure by following the instructions below.**

### **Full Frame Anchoring System**

1. Loosen the rail lock nuts and remove the rail spacer wedges from all four anchoring stands.



**2. IMPORTANT!** Remove the wedges from the top of the anchoring stand on all four stands so that the cross beams may rotate freely on the anchoring stands before jacking or lowering the car.

3. Remove the wedges on the 6' (1.83 m) anchoring sidebar between the front and rear clamps and remove the bars.
4. Raise the rear end of the vehicle enough so that the ends of the crossbeams are higher than the ears of the anchoring stand. Support using jack or wheel stands then remove R7 stands.
5. Place floor jack (using centre pin) under crossbeam to support weight. Remove the wedges from the bottom of the swivel clamps. Remove the crossbeam and then the swivel clamps and lower vehicle. Repeat the same procedure for the front end of the vehicle.

# PARTS DIAGRAM

## Swivel Base Assembly

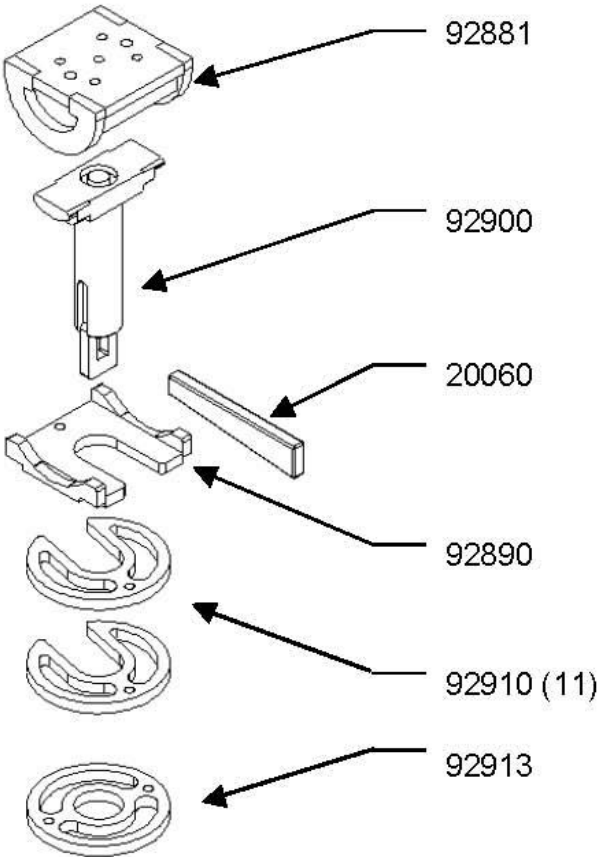

# PARTS DIAGRAM

## Box Frame Adapter

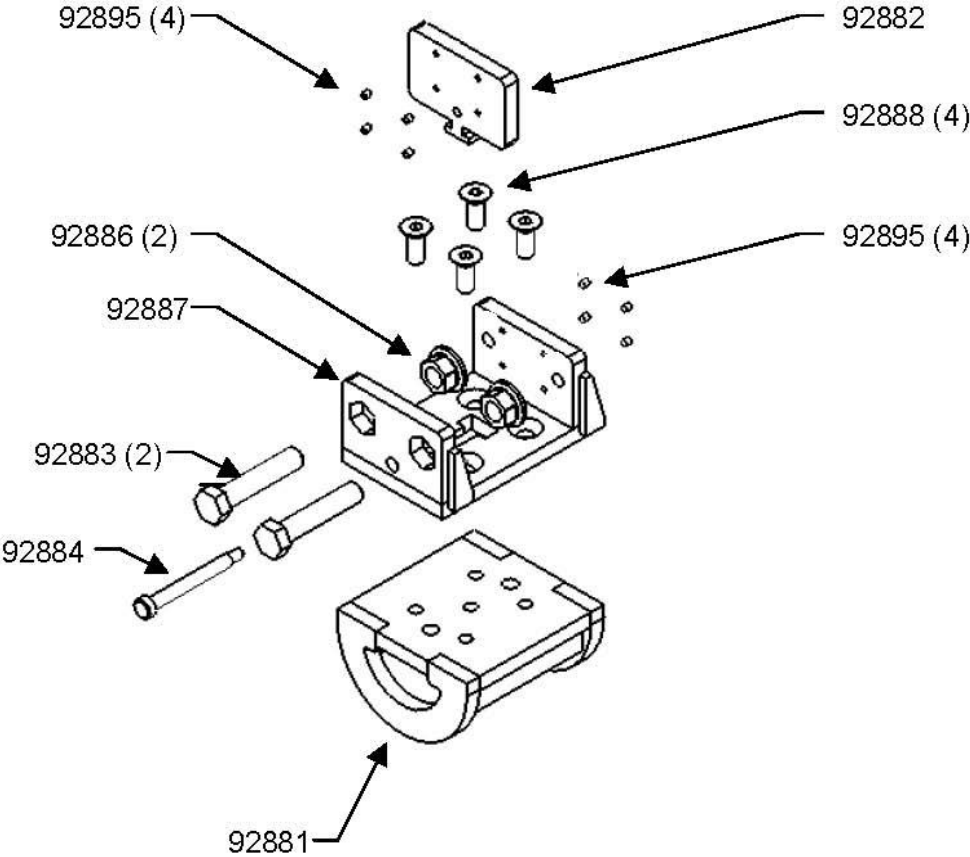

**PARTS DIAGRAM**

**C – Section Adapter**

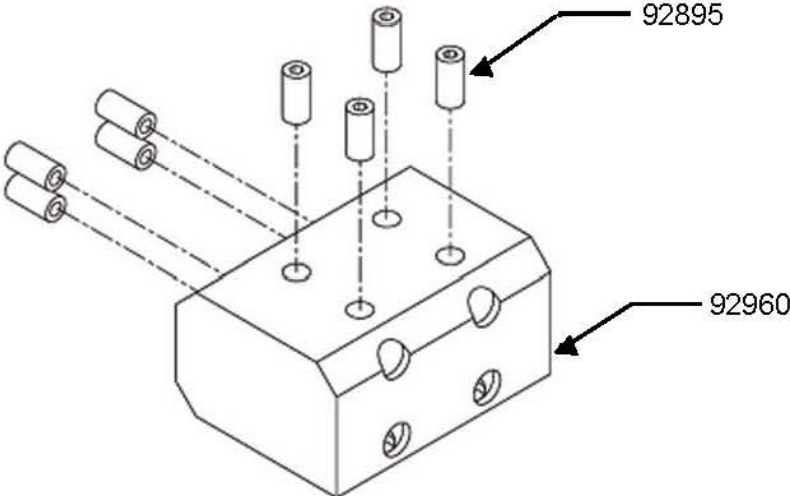

**Leaf Spring and Torsion Bar Adapter**

