



# MONOCOQUE PULLING TOWER

**PART NOs. 94000 & 94100**

## **ASSEMBLY & OPERATION INSTRUCTIONS**

	Page
Introduction .....	1
Assembly Instructions .....	2
Important Safety Information .....	6
Basic Operation of Monocoque Tower .....	10
Accessories for the Monocoque Tower .....	14
Replacement Parts Diagram and Listing .....	17

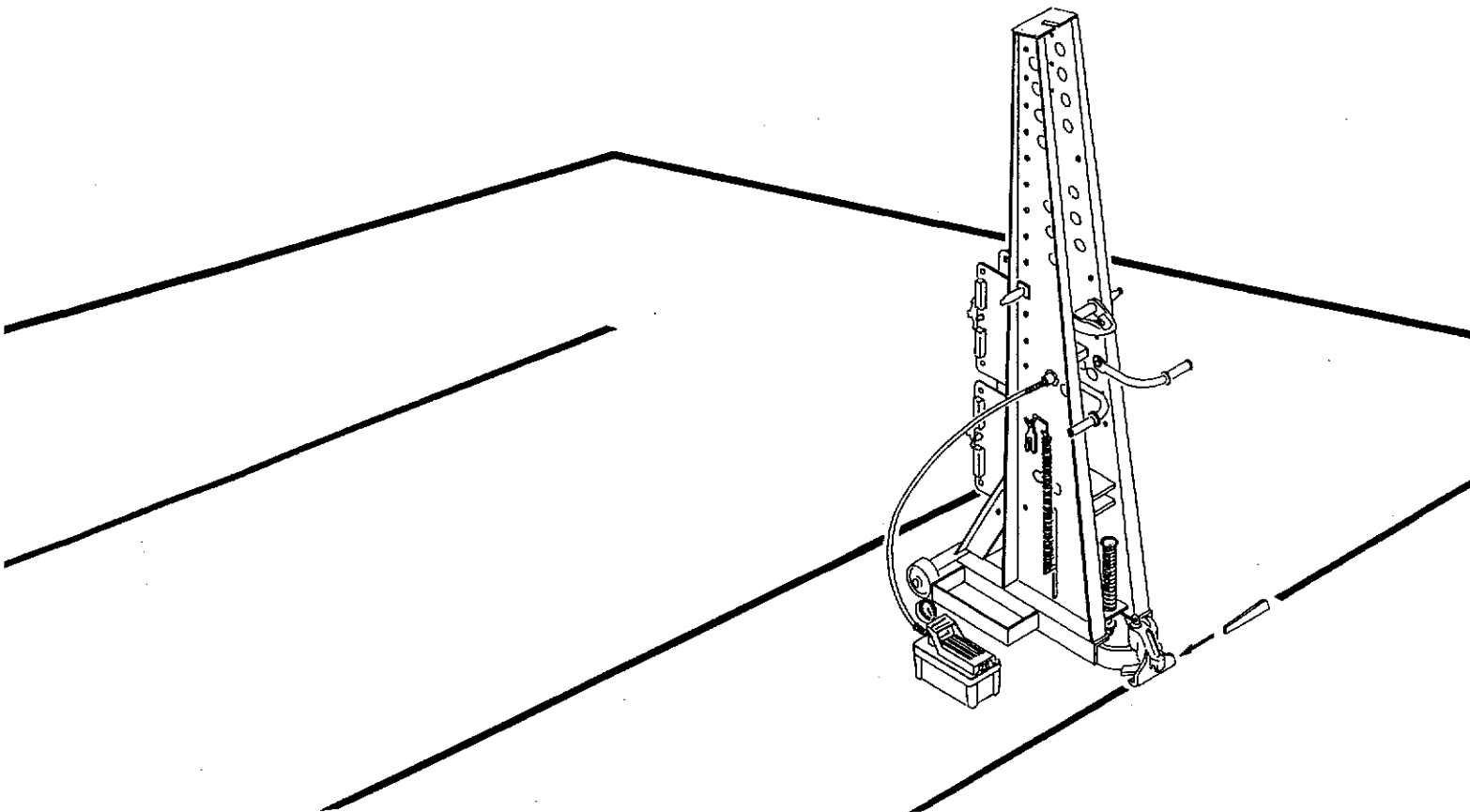

**⚠ WARNING :**

- All safety precaution statements on the air/hydraulic pump operating instructions supplied must be carefully observed to help prevent personal injury.

## **INTRODUCTION**

**The Monocoque Tower Pulling Machine was designed to be used with the Wedge Clamp aluminum floor anchoring rails.**

### **SPECIAL FEATURES**

- Full 10 ton pulling power
- Works in 12'2" (3.7 m) wide work bays
- 60" (1.52 m) maximum pull height capability (See Page 9 for safety notice)
- Makes double pulls simultaneously, and the ability to lock out either pull while the other pull continue
- Easy to change pull heights
- Pulling at angle to the rail is permitted with the special rail tie-down
- Spring loaded rear swivel wheel allows easy movement and positioning of the tower
- Pressure monitoring gauge on hydraulic pump
- 16' (4.88 m) long pulling chain
- Uses high grade tempered alloy chain
- Equipped with two alloy pull hooks
- Extensively tested for strength and functioning
- Uses lightweight tempered aluminum pulleys
- Quick return springs on hydraulic cylinder
- Easy to add "come-along" additional pulling
- Engine lift arm available as accessory for upward pulling over the vehicle
- Make multi pulls with Back Brace Kit accessory
- Quick rail connection with drop pin
- All zinc coated for long lasting appearance

# ASSEMBLY INSTRUCTIONS

# 1

- Position the two handle assemblies so that the handle arm forms a 90° angle with the back of the tower as shown.

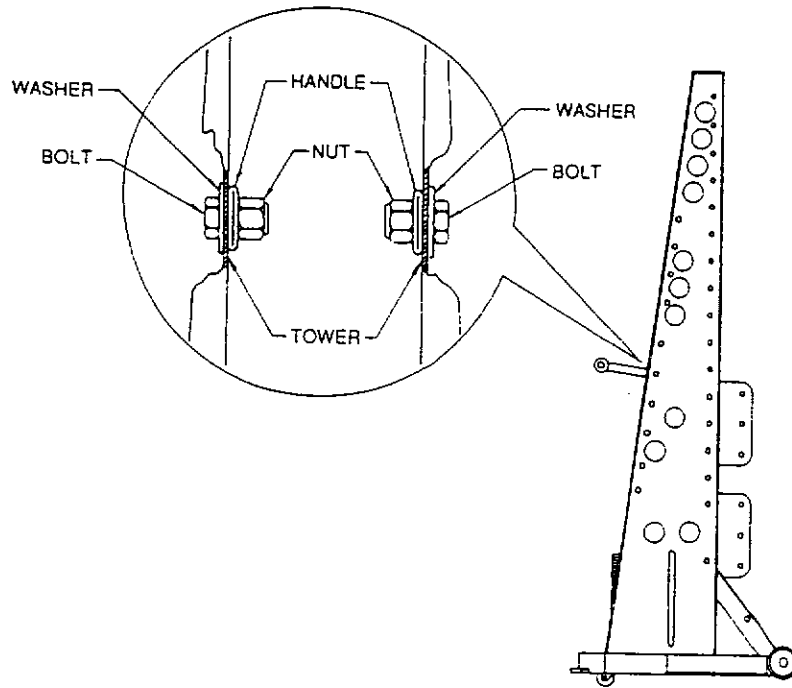

# 2

- Pulleys may be positioned in any of the holes along the front edge.

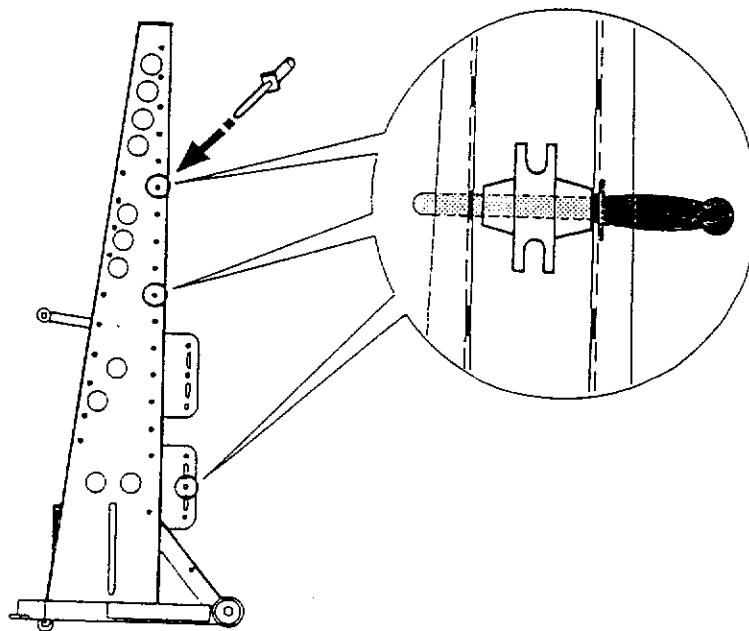

## ASSEMBLY INSTRUCTIONS

- 3** • The anti-roll springs are used to prevent the chain from rolling backward off the pulley. It is useful to use these springs when pulleys are in the higher positions on the tower.

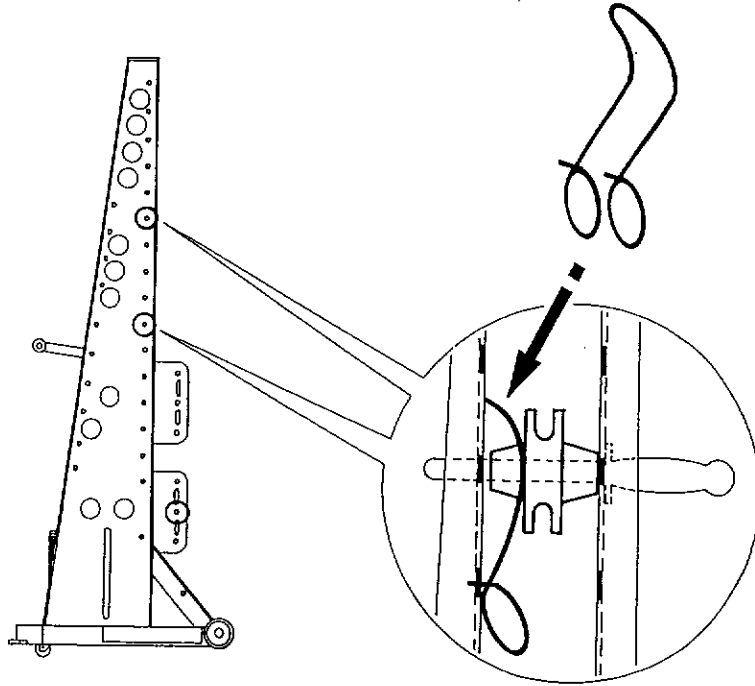

- 4** • Locate the Chain Lock onto the tower as shown, one each side.

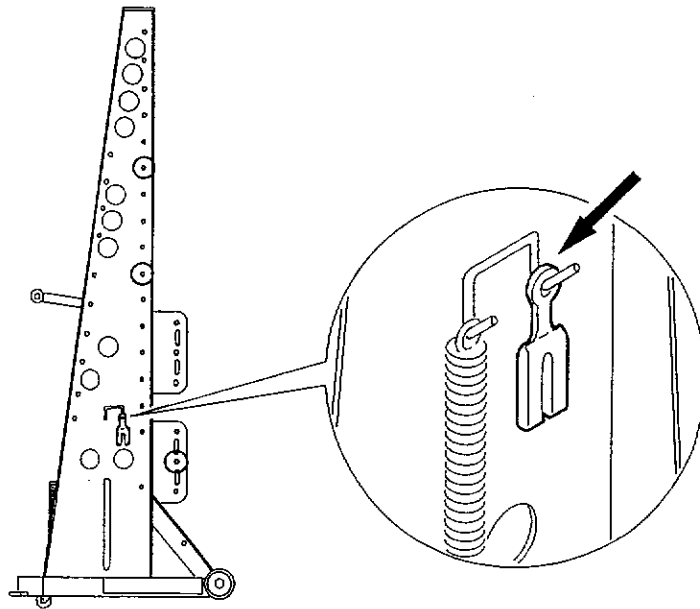

# ASSEMBLY INSTRUCTIONS

## 5

### Standard Chain/Pulley Set Up

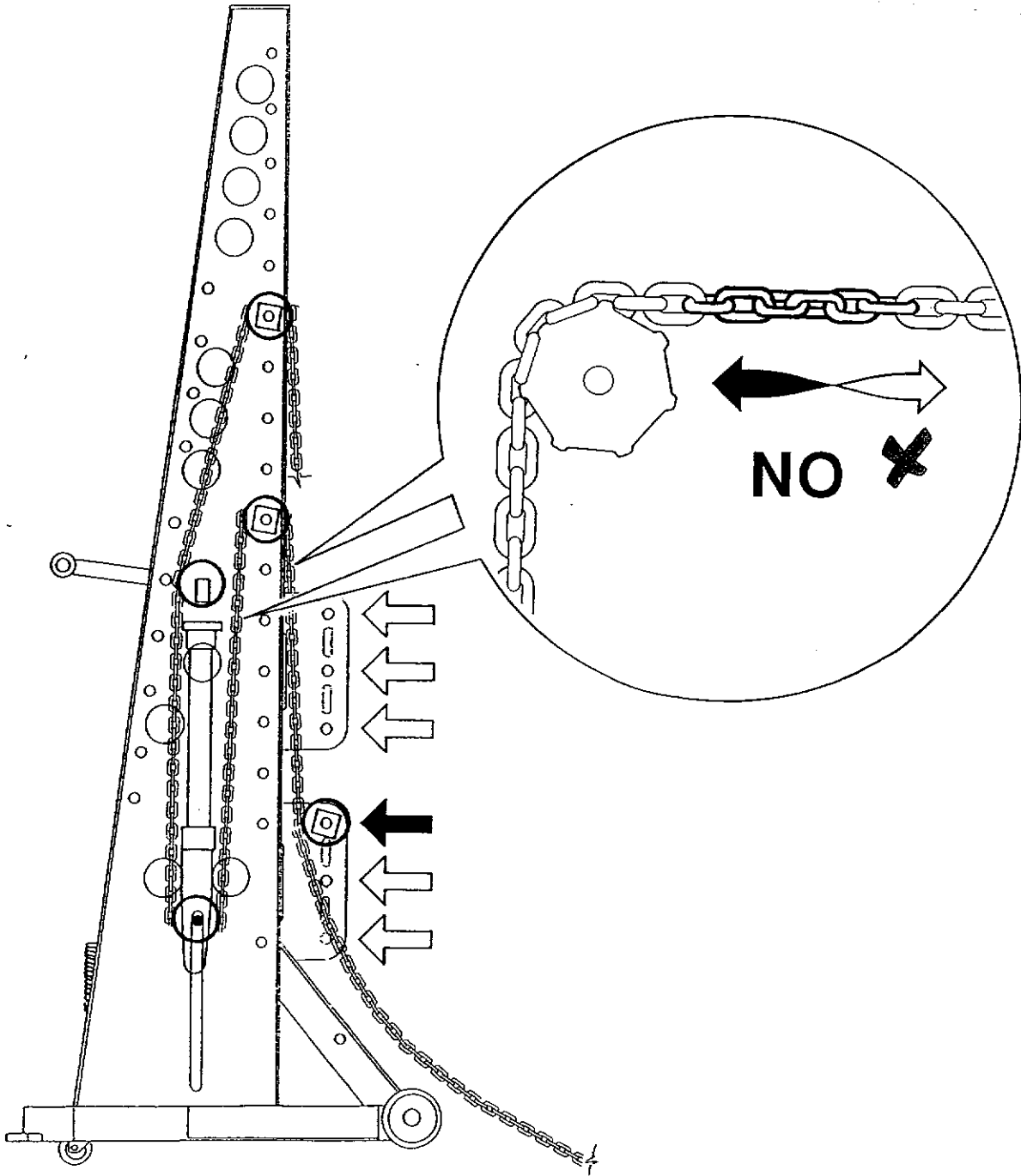

**⚠ WARNING:** Be sure that there are no twists in the chain.

## ASSEMBLY INSTRUCTIONS

# 6

- Place the Chain Tie Back, Rail Tie Down, Tie Down Pin, Locking Wedge, 3/4" Bolt and Nut in the tray.

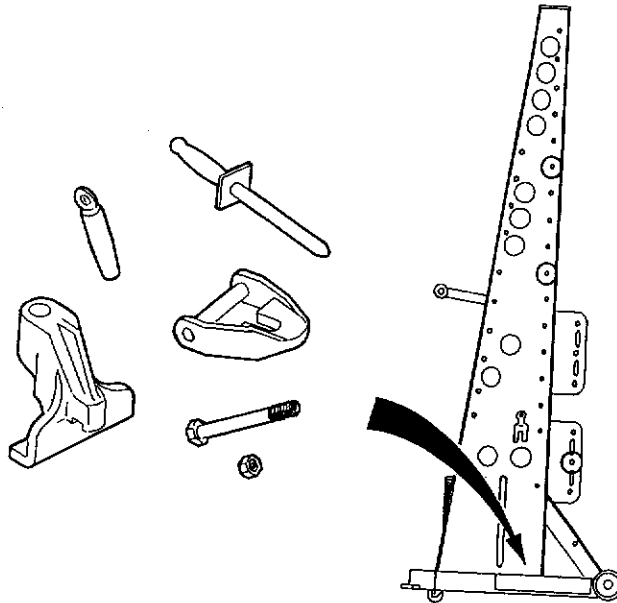

# 7

- Attach the Hydraulic Pump Hose to the Hydraulic Ram as shown.

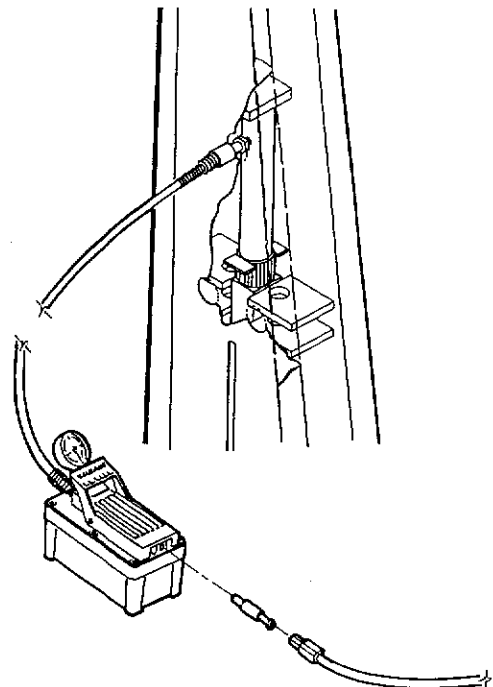
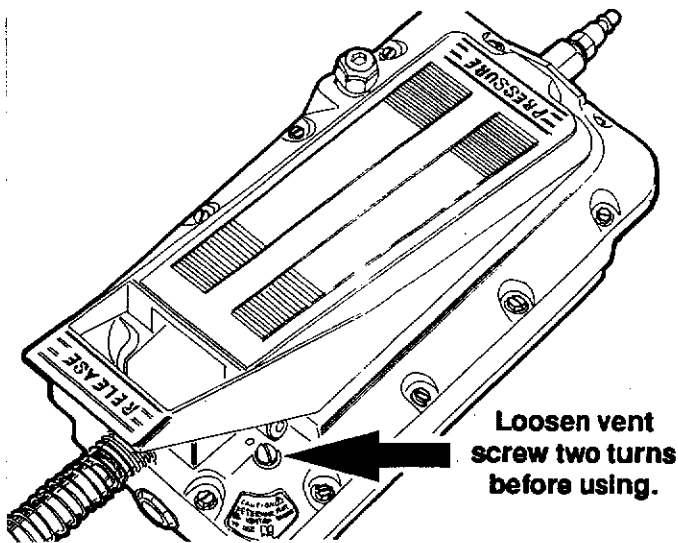

## IMPORTANT SAFETY INFORMATION

- There is great upward pressure at the floor anchoring point. The floor rail anchoring method must be secure. We recommend one of the following anchoring rail methods.

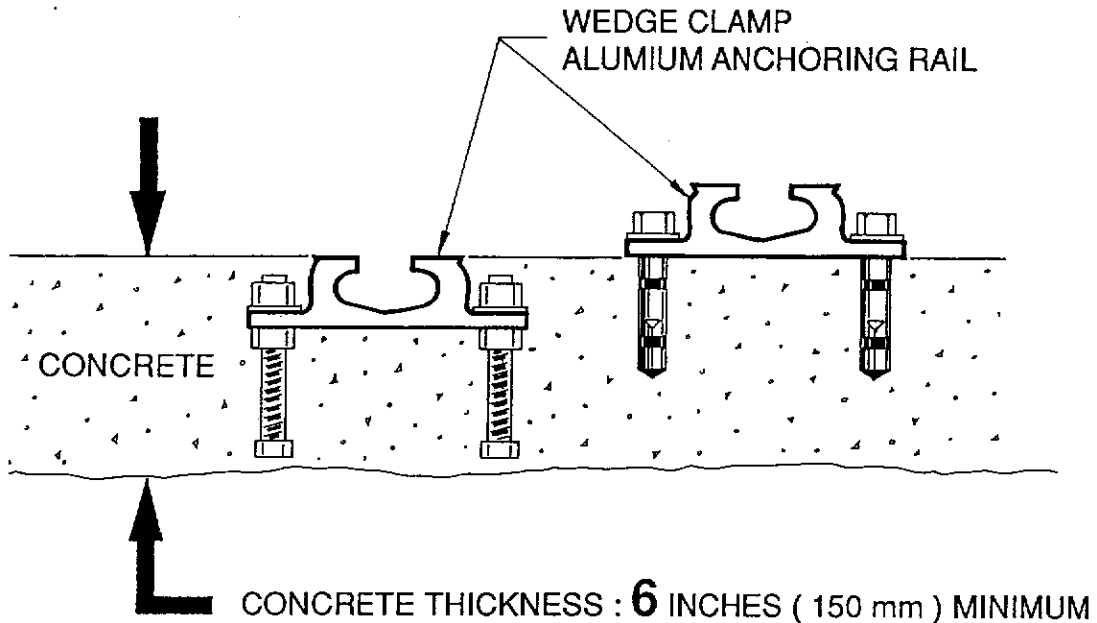

### **⚠ WARNING:**

- The Rail Tie Down must always be used to anchor the tower to the floor rail before making any pull. Always insert the Tie Down Pin, and install the Locking Wedge by hammering the wedge into the slot as shown to prevent possible sideways movement of the tower.
- To lower the tower for flush mounted rails push down on the back edge of the tower. The spring suspension in the rear wheel will allow the tower to be lowered.

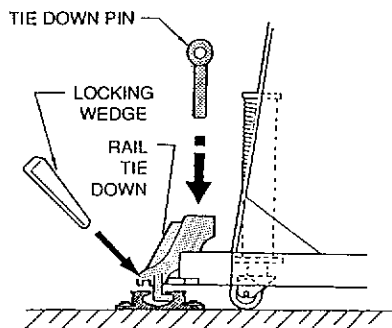

**SURFACE MOUNTED RAIL**

**OR**

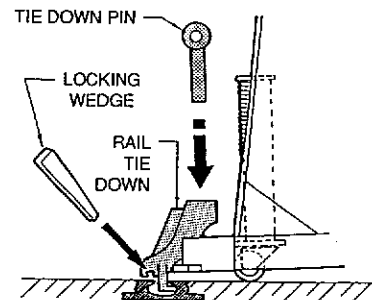

**FLUSH MOUNTED RAIL**

## IMPORTANT SAFETY INFORMATION

### **WARNING**

- Airline pressure should never be greater than 110 P.S.I. (7.5 bar, 758 kPa). Pressure over 110 P.S.I. can cause the hydraulic ram to overpull which can result in breakage and risk of personal injury.

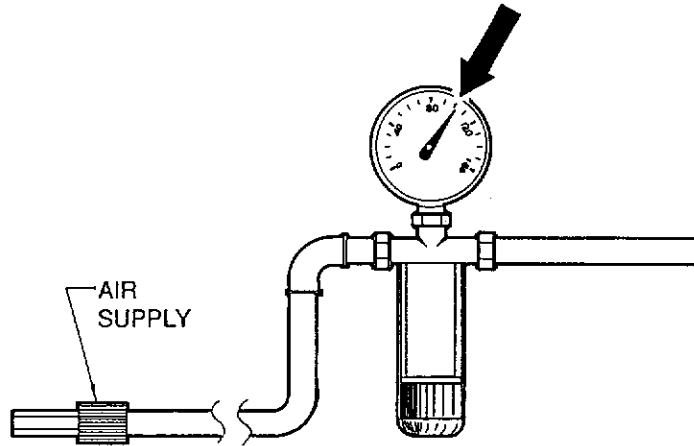

- Check and review safety decals on the tower.

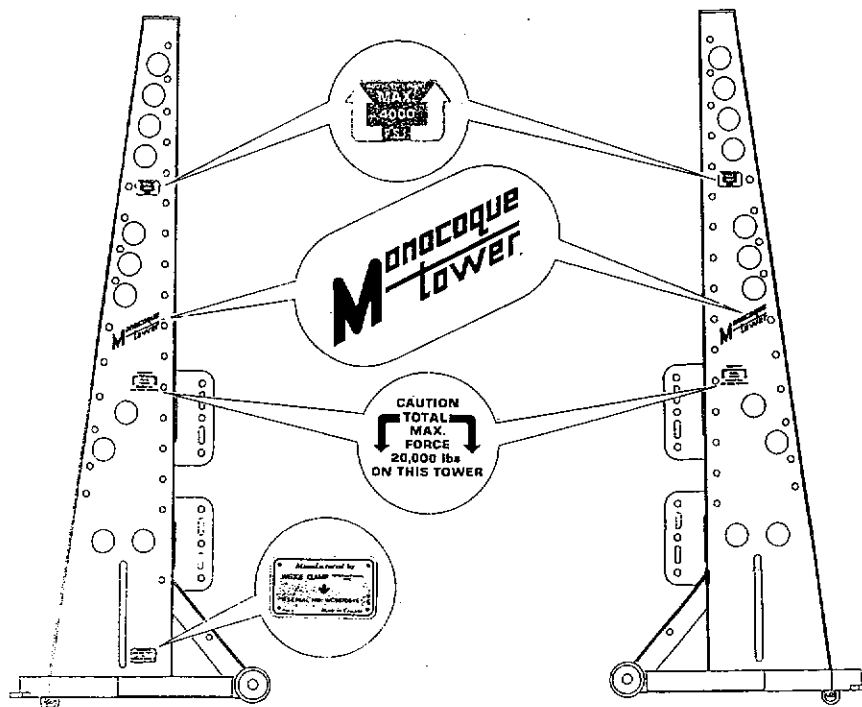

## IMPORTANT SAFETY INFORMATION

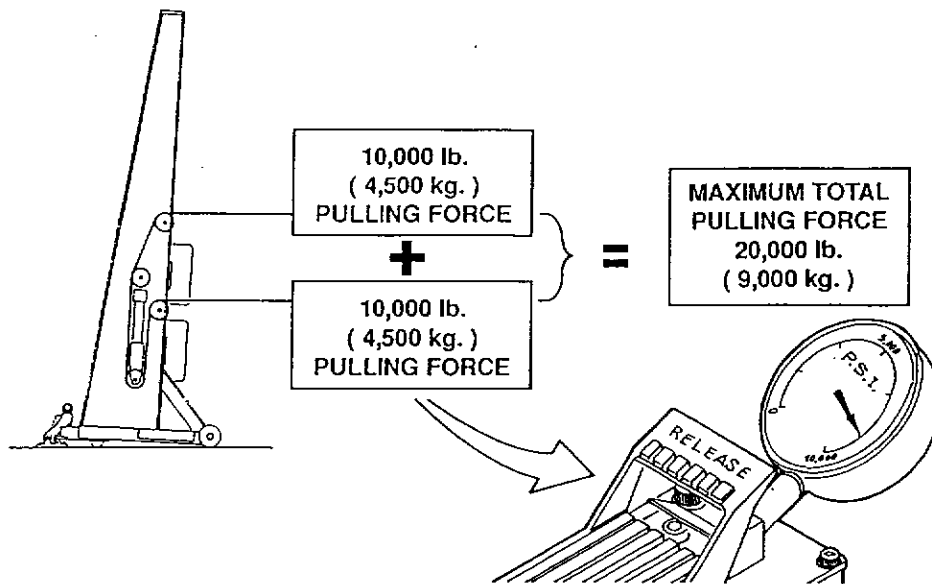

### **! WARNING :**

- Do not exceed 20,000 lb. ( 9,000 kg ) total pulling force on tower (8,900 P.S.I. on hydraulic gauge = 20,000 lbs. force at the ram ).
- Never exceed 4,000 lb. ( 1,800 kg ) total pulling force above 60" ( 1.52 m ) height on the tower.
- Never stand close to the tower when pulling.

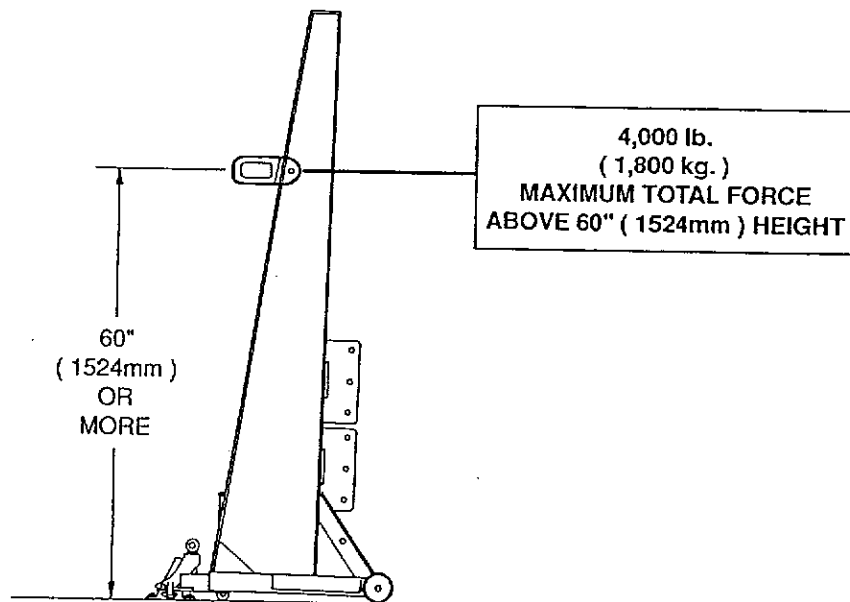

## IMPORTANT SAFETY INFORMATION

### CAUTION

- Never have the pulling chain routed directly to the ram pulley. If a low pulling height is required the chain must be routed as shown on the right.

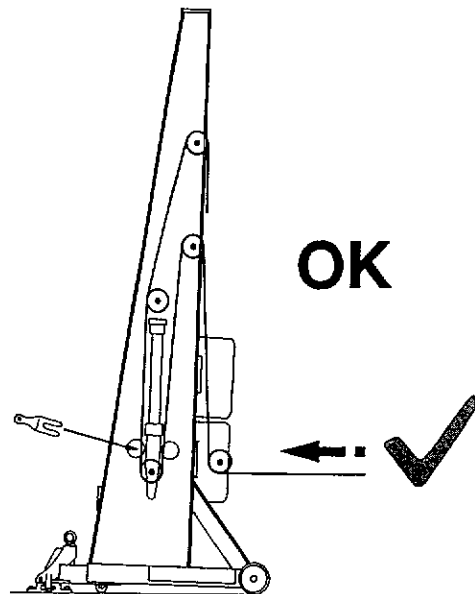
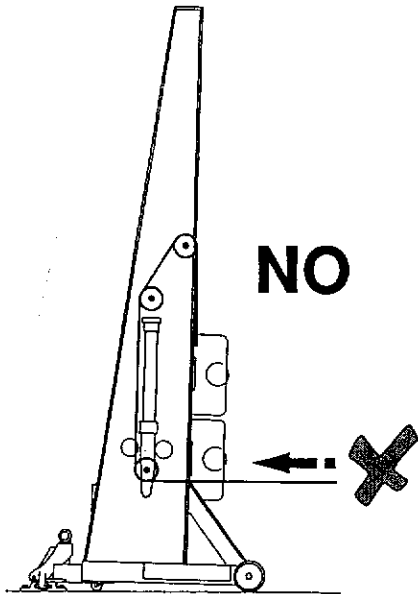

### WARNING

- Always remove any twists in the chains.

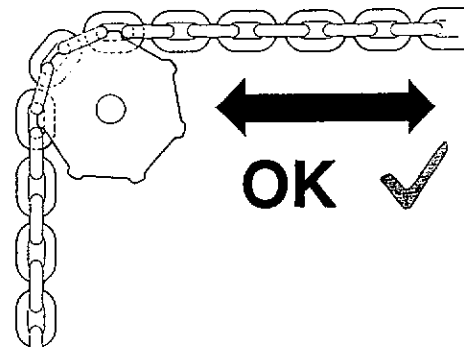
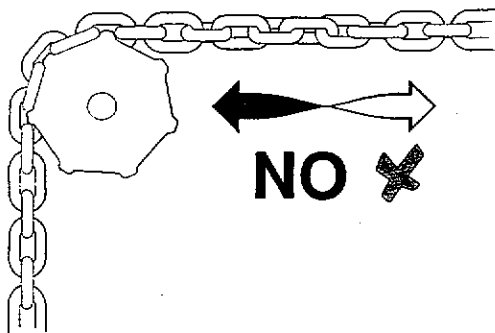

## BASIC OPERATION OF MONOCOQUE TOWER

### Chain

- For standard pulls, position the Chain as shown.

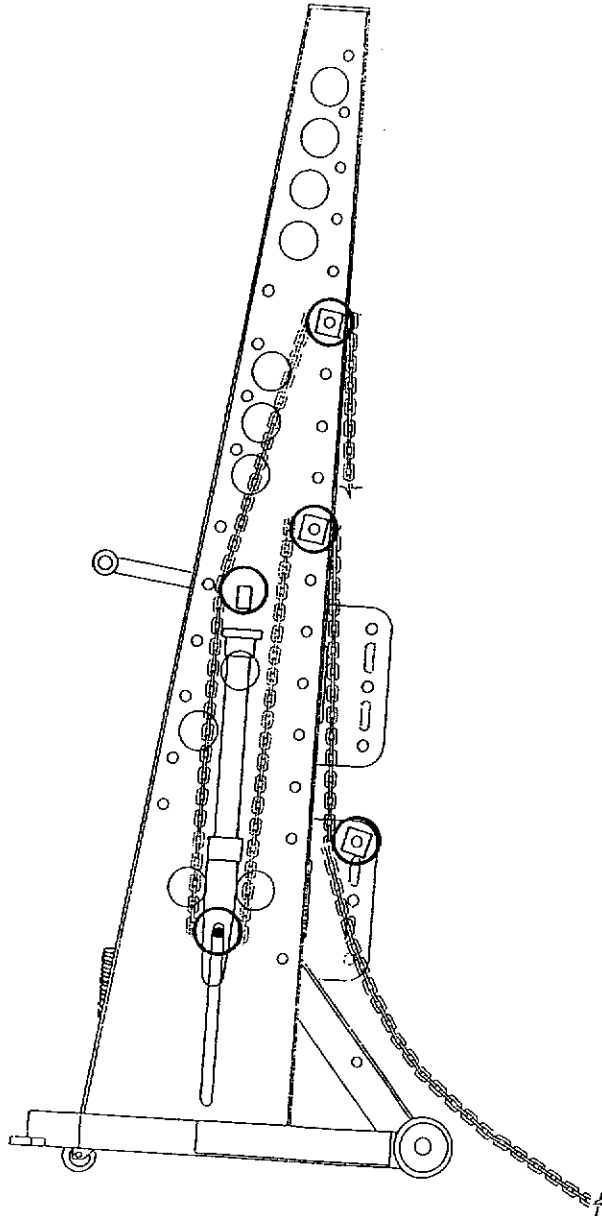

**Standard Pulls**

## BASIC OPERATION OF MONOCOQUE TOWER

### Chain

- For double pulls, position the Chain as shown.

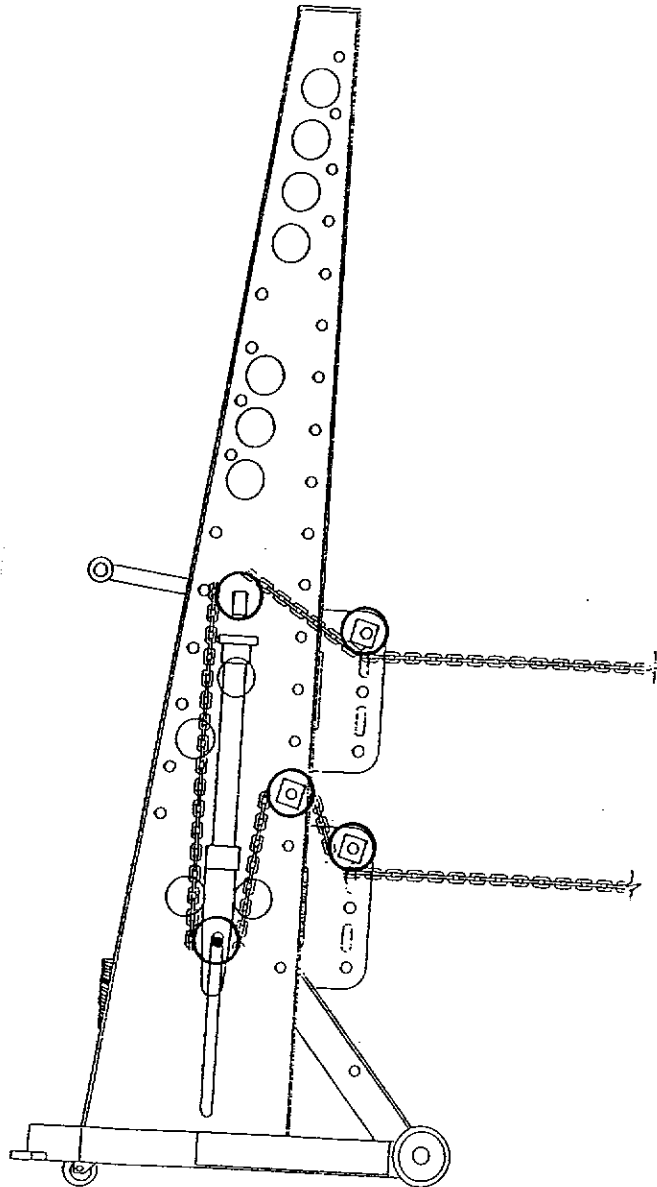

**Double Pulls**

## BASIC OPERATION OF MONOCOQUE TOWER

### Chain Lock(s)

- When pulling on only one chain, insert the chain lock through the appropriate lockout hole as shown.

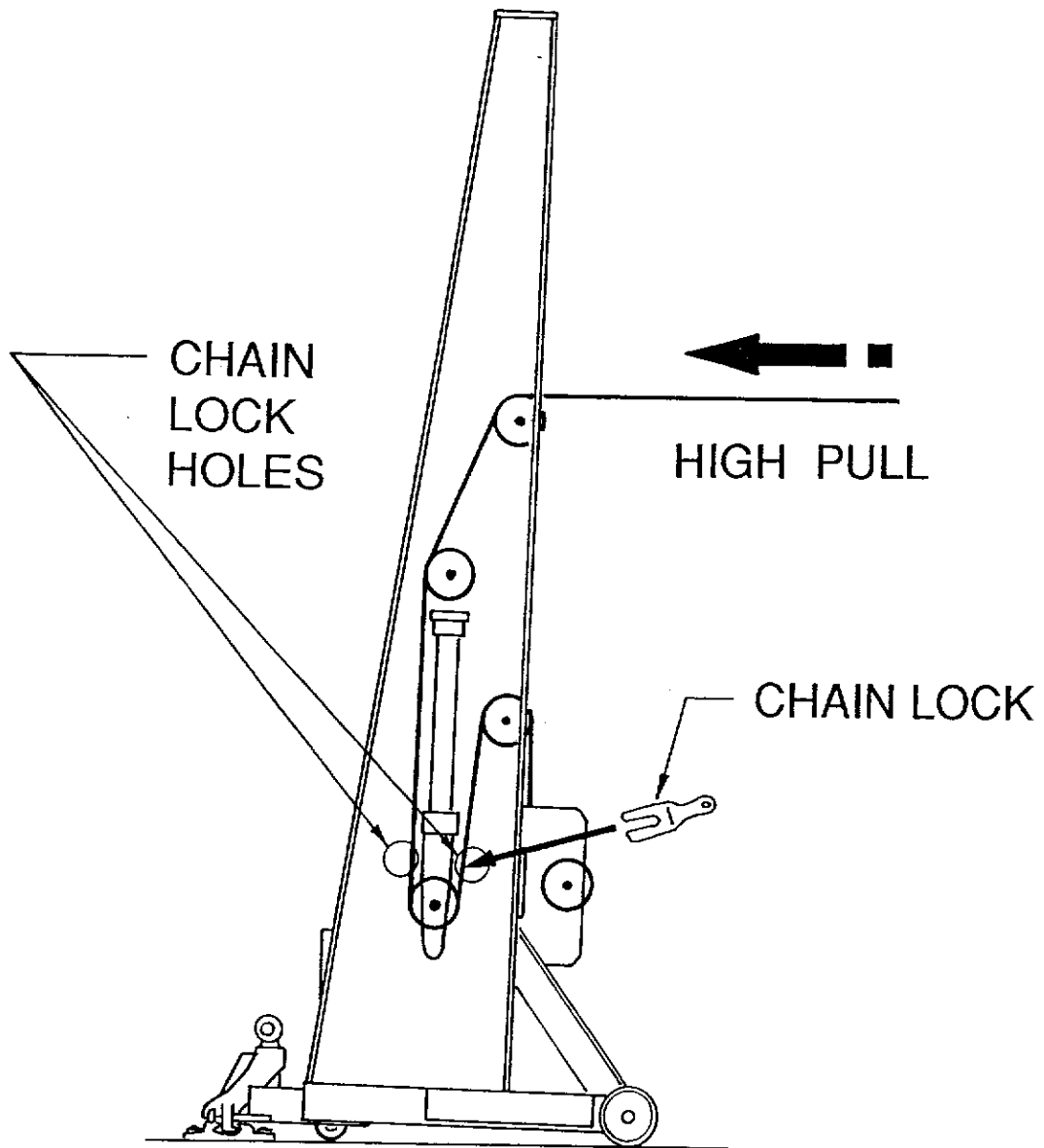

## BASIC OPERATION OF MONOCOQUE TOWER

### Chain Lock(s)

- When pulling on only one chain, insert the chain lock through the appropriate lockout hole as shown.

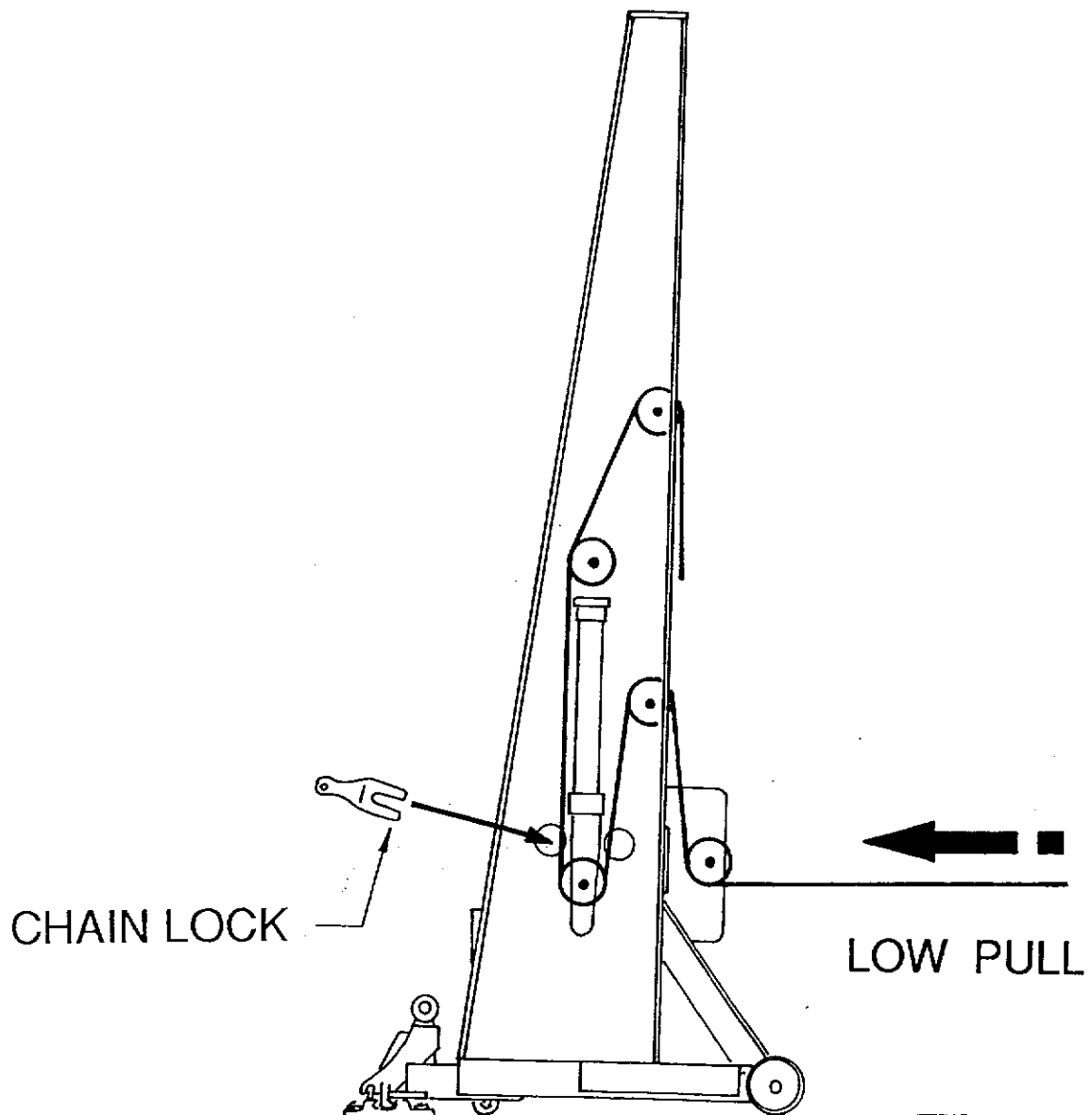

## ACCESSORIES FOR THE MONOCOQUE TOWER

### Back Brace Kit

Part No. 20600

- Two Monocoque Towers can be linked together with the back brace to allow additional pulls to be made between the towers.

### WARNING :

- Never exceed maximum total pulling force of 20,000 lb (9,000 kg) on any tower, and never exceed 4,000 lb. (1,800 kg) above 60" (1.52 m) height on any tower.

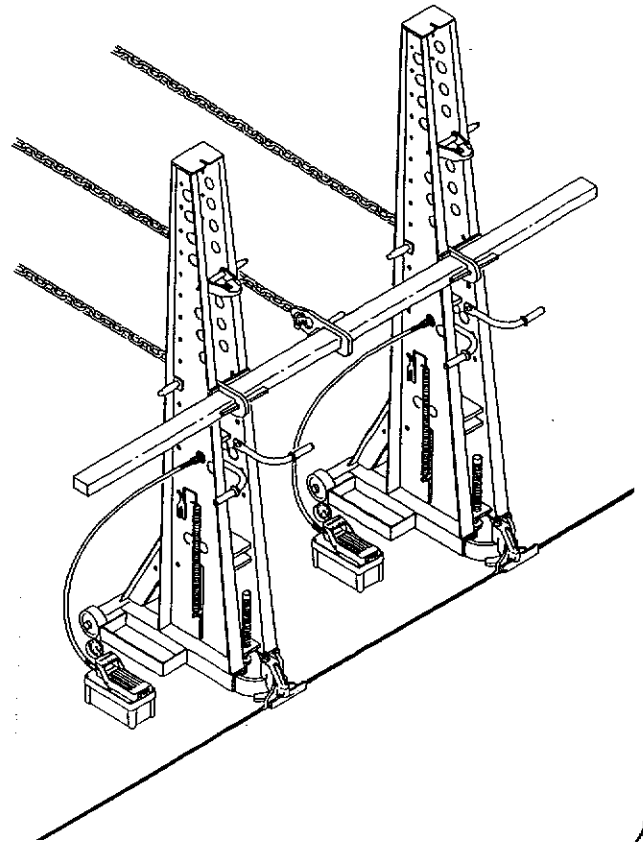

### Back Brace Kit Components (Part No. 20600)

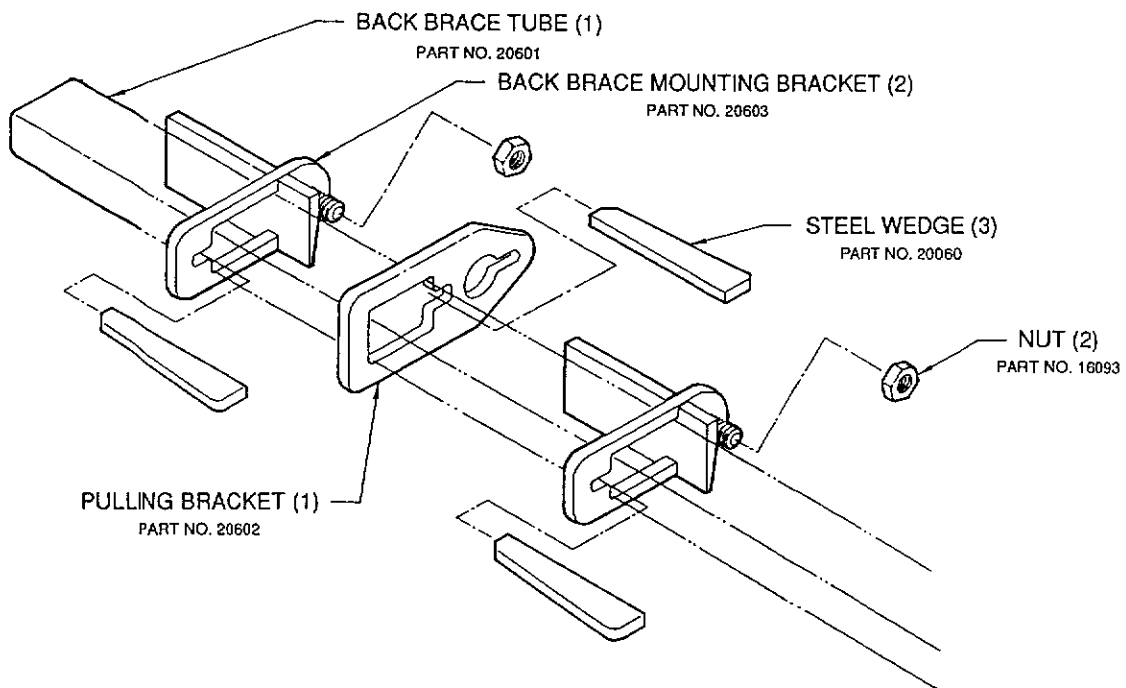

## Engine Lift Accessory Kit.

Part No. 20500 (uses 5/16" chain)

Part No. 21500 (uses 3/8" chain)

- The Engine Lift Accessory allows the Monocoque Tower to be used for vertical lifting or pulling using the tower's hydraulics.

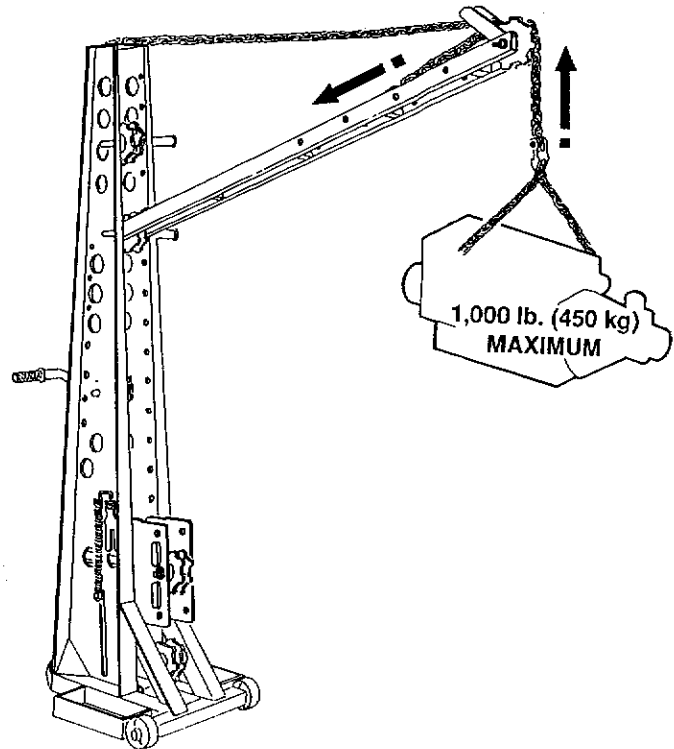

### **WARNING :**

- Do not exceed lifting weight of 1,000 lb. (450 kg).

## Engine Lift Accessory components

Part No. 20500 ( 5/16" chain )

Part No. 21500 (3/8" chain )

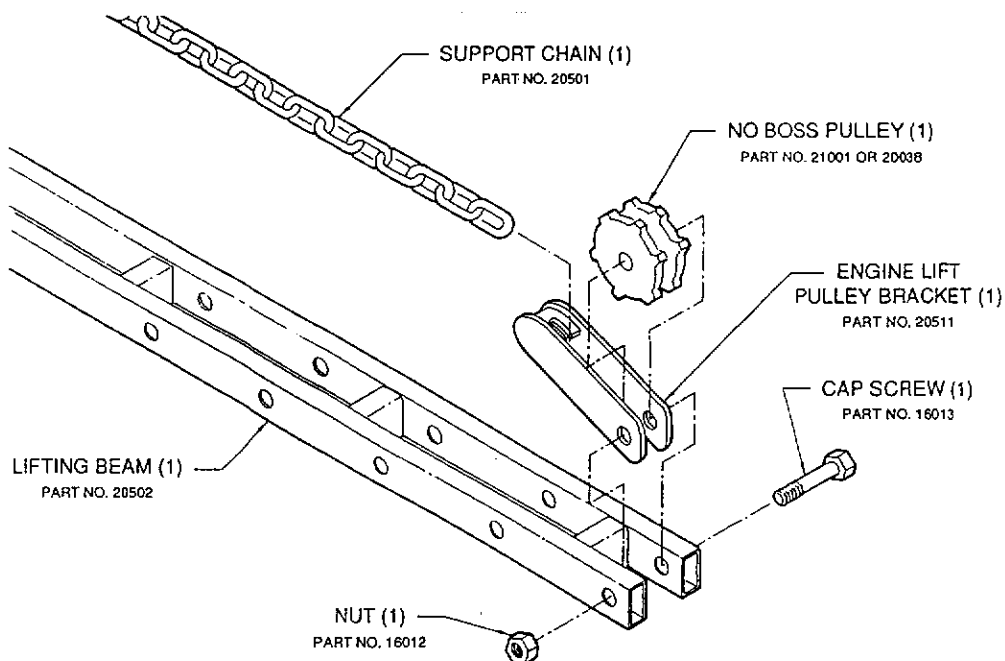



# MONOCOQUE TOWER

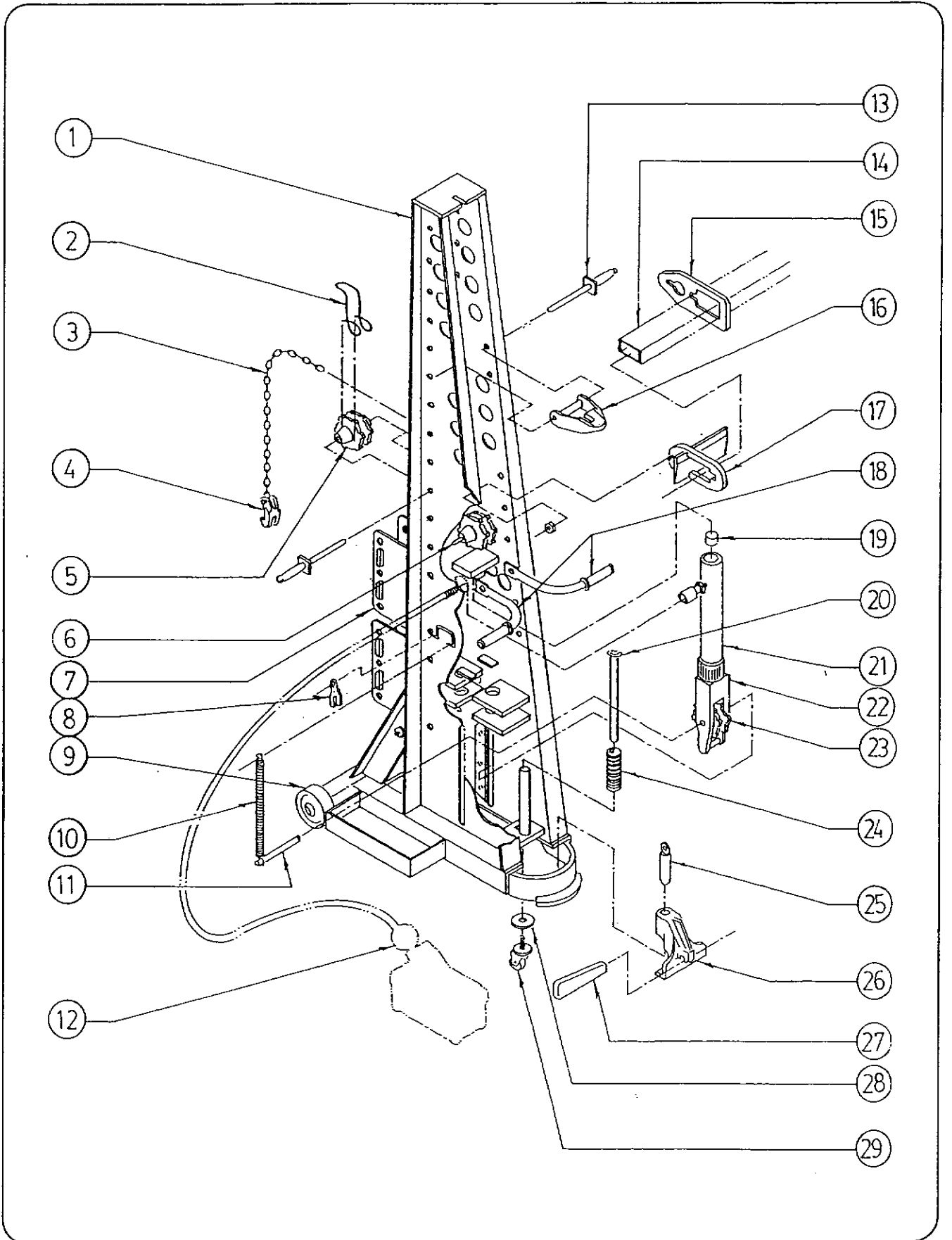

## REPLACEMENT PARTS LIST

ITEM NO.	PART NO.	NO. REQ'D	DESCRIPTION
1.	20015	1	MAIN FRAME ASSY.
2.	20063	2	PULLEY SPRING
3.	20106	1	CHAIN 5/16" X 16'
	21008	Optional	CHAIN 3/8" X 16'
4.	20104	1	5/16" CLAW HOOK
	21005	Optional	3/8" CLAW HOOK
	21006	Optional	3/8" CLEVIS SLIP HOOK
	21007	Optional	3/8" CLEVIS GRAB HOOK
5.	20039	4	5/16" PULLEY BOSS
	21002	Optional	3/8" PULLEY BOSS
6.	20010	1	PULLEY SHAFT
7.	20047	2	LOW PULL BRACKETS
8.	20061	2	CHAIN LOCK
9.	20001	2	4" CAST WHEEL
10.	20003	2	CYL. RETURN SPRING
11.	20005	1	SPRING PULLEY SHAFT
12.	20054	1	PUMP
	20053	1	HOSE
	20111	1	TEE
	20112	1	ELBOW
	20113	1	GAUGE
13.	20055	3	PULLEY PIN
14.	20601	Optional	BACKBRACE TUBE
15.	20602	Optional	ADD PULL BRACKET
16.	20056	1	CHAIN TIE BACK
17.	20603	Optional	BACKBRACE MOUNTING BRACKET
18.	20057	2	HANDLE (MOBILITY) ASSY.
19.	20013	1	RAM CENTERING PLUG
20.	20008	1	CASTOR SHAFT
21.	20014	1	HYDRAULIC RAM
21.	20037	1	PULLEY BRACKET
23.	20038	1	5/16" PULLEY FLAT
	21001	Optional	3/8" PULLEY FLAT
24.	20007	1	SPRING
25.	20059	1	TIE DOWN PIN
26.	20058	1	RAIL TIE DOWN
27.	20060	1	LOCKING WEDGE
28.	16011	1	CASTOR WASHER
29.	20009	1	CASTOR WHEEL